

## ENGINE

Make	FPT
Model	F4HFE613
Emissions Certification	Tier 4 Final
Type	4-stroke, turbocharged and air-to-air cooled
Cylinders	6-cylinder in-line
Bore/Stroke	4.09 x 5.20 in (104 X 132 mm)
Displacement	411 in <sup>3</sup> (6.7 L)
Fuel	#2 Diesel, #1 and #2 mixture permitted for cold temperatures
Fuel injection	Direct injection – electronic
Fuel filter	Replaceable, full flow spin-on cartridge
Fuel pump	Bosch CP 3.3
Gradeability:	
Side-to-side	35°
Fore and aft	35°
Air filter	2-element dry-type w/ warning restriction indicator
Mid-mount cooling module:	Mid-mount air/water
Fan – hydraulic driven:	
Style	8 blade puller
Diameter	32 in (813 mm)
Water pump	Integral
Engine oil pump operating angles ratings:	
Side-to-side	35°
Fore and aft	35°
Oil filtration	Replaceable, full flow spin-on cartridge
Engine speeds	RPM
Rated – full load	2000
Horsepower:	
Maximum Power Mode:	
Peak gross @ 1800 RPM	231 hp (172 kW)
Net rated @ 2000 RPM	205 hp (153 kW)
Peak net @ 1800 RPM	212 hp (158 kW)
Standard Power Mode:	
Peak gross @ 1700 RPM	208 hp (155 kW)
Net rated @ 2000 RPM	178 hp (133 kW)
Peak net @ 1700 RPM	193 hp (144 kW)
Economy Power Mode:	
Peak gross @ 1400 RPM	169 hp (126 kW)
Net rated @ 2000 RPM	123 hp (92 kW)
Peak net @ 1400 RPM	161 hp (120 kW)

NOTE: Gross horsepower and torque per SAE J1995.  
Net horsepower and torque per SAE J1349.

## ENGINE (cont.)

Torque – peak:	
Maximum Power Mode:	
Gross @ 1300 RPM	873 lb-ft (1 184 N·m)
Net @ 1300 RPM	844 lb-ft (1 145 N·m)
Standard Power Mode:	
Gross @ 1300 RPM	745 lb-ft (1 010 N·m)
Net @ 1300 RPM	716 lb-ft (971 N·m)
Economy Power Mode:	
Gross @ 1300 RPM	664 lb-ft (900 N·m)
Net @ 1300 RPM	635 lb-ft (861 N·m)

Torque rise:	
Maximum power range	47%

NOTE: Gross horsepower and torque per SAE J1995.  
Net horsepower and torque per SAE J1349.

## DRIVETRAIN

Transmission:	
4F/3R Proportional w/ Electronic Control Module torque sensing autoshift/manual shift and modulation	
Gears	Helical cut
Torque converter:	
Stall ratio – 4-speed	2.28:1
Stall ratio – 5-speed	2.42:1
Differential:	
Limited slip differential, front – up to 72.5% of available axle torque to wheel w/ traction	
Limited slip differential, rear – up to 72.5% of available axle torque to wheel w/ traction	
Rear axle oscillation	24° total
Front and rear axles:	
Differential ratio	4.11
Planetary ratio	6.00
Final axle ratio	24.67

Heavy-duty axles – optional:	
Front axle equipped w/ locking differential	
Rear axle equipped w/ open differential	

Planetaries	Outboard
-------------	----------

Service brakes:	
Hydraulically actuated, maintenance-free, multiple wet disc w/ accumulator to all four wheels	
Brake surface area:	
Rear hub	600 in <sup>2</sup> (0.387 m <sup>2</sup> )
Front and opt. rear hub	721 in <sup>2</sup> (0.465 m <sup>2</sup> )

Parking brakes:	
Spring-applied hydraulic release disc on transmission output shaft neutralizes power flow to wheels when engaged	

Travel speeds – 4-speed transmission:		
	Forward	Reverse
	mph (kph)	mph (kph)
1st	4.4 (7.1)	4.7 (7.5)
2nd	7.5 (12.0)	7.8 (12.6)
3rd	14.5 (23.3)	15.2 (24.4)
4th	22.7 (36.6)	–

NOTE: Travel speeds at full engine throttle w/ 23.5 x 25 L3 tires.

## DRIVETRAIN (cont.)

Travel speeds – 5-speed transmission:		
	Forward	Reverse
	mph (kph)	mph (kph)
1st	4.1 (6.6)	4.3 (7.0)
2nd	7.1 (11.4)	7.5 (12.0)
3rd	10.6 (17.1)	17.2 (27.7)
4th	16.4 (26.4)	–
5th	24.8 (40.0)	–

NOTE: Travel speeds at full engine throttle w/ 23.5 x 25 L3 tires.

## ELECTRICAL

Voltage	24 Volts, negative ground
Alternator	120 amp
Batteries (2)	12-volt

## OPERATOR ENVIRONMENT

ROPS/FOPS Cab w/ heat and AC; Key start; Articulated power steering w/ tilt column; Fully adjustable suspension seat; Foot throttle; 1-Lever loader control w/ wrist rest; Cup holder; Coat hook; 1 Interior rearview mirror; 2 in (51 mm) retractable seat belt; Storage tray behind seat; Lunch box compartment; Single brake pedal; F-N-R shuttle switch; Glove box; Pressurized air filtering; Anti-glare window strip; Defroster; Side window partial/fully open; Dome light; Wipers, rear and intermittent front; Windshield washers, front and rear; Rubber floor mat; Horn.

Displays/Gauges:  
Analog:  
Transmission oil temperature; Hydraulic oil temperature; Fuel level; Engine coolant temperature.

LCD screen:  
Hour meter; Engine speed; Travel speed; Time; Automatic transmission indication; Current gear selection; FNR indication; DeClutch indication; Engine mode indication; Trip computer; Fuel consumption; Multiple languages, Metric/English; Engine diagnostics; Transmission diagnostics; Warning prompts; Error reporting; DEF gauge; Diff. Lock\*.

Audible/Visual alarms:  
Warning lights:  
Four-way flashers and turn signals; Brake pressure; Lamp/high beam indication; Grid heater\*.

NOTE: \*If equipped w/ option.

## OPERATOR ENVIRONMENT (cont.)

### Audible/Visual alarms:

#### Caution alarm:

Parking brake; Coolant temperature; Hydraulic oil temperature; Transmission oil temperature; Air filter; Transmission filter; Hydraulic filter; Alternator; Low fuel.

#### Critical alarm:

Engine oil pressure; Brake pressure; Steering pressure – w/ aux steering\*; Coolant temperature; Hydraulic oil temperature; Transmission oil temperature.

#### Backup alarm

NOTE: \*If equipped w/ option.

## OPERATING WEIGHT

### Z-Bar

Unit equipped w/ 23.5R25 Michelin XHA2; ROPS cab w/ heater and AC; Heavy-duty counterweight – 4,940 lb (2 241 kg); Heavy-duty batteries; Front and rear fenders; Lights; Full fuel; 175 lb (79 kg) operator; 4.25 yd<sup>3</sup> (3.2 m<sup>3</sup>) MD pin on w/ bolt on edge:

38,874 lb (17 633 kg)

### XR

Unit equipped w/ 23.5R25 Michelin XHA2; ROPS cab w/ heater and AC; Heavy-duty counterweight – 4,940 lb (2 240 kg); Heavy-duty batteries; Front and rear fenders; Lights; Full fuel; 175 lb (79 kg) operator; 4.25 yd<sup>3</sup> (3.2 m<sup>3</sup>) MD pin on w/ bolt on edge:

39,716 lb (18 015 kg)

## HYDRAULICS

### Pump – steering/implement:

Closed center pressure/flow compensated

### Variable displacement – load sensing:

31.7 gpm @ 2000 RPM  
(120 L/min @ 2000 RPM)

### Loader control valve:

Closed-center, sectional 2, 3 or 4-function w/ pilot control for lift, tilt and auxiliary hydraulics, electromagnetic detents in float, raise and rollback

### Loader auxiliary steering:

Hydraulic orbital center-pivot articulating w/ on-demand oil flow

### High pressure standby:

Implement 3,625 psi (25 000 kPa)  
Steering 3,499 psi (24 132 kPa)

### Filtration:

Filtered vent w/ relief on hydraulic reservoir, maintains 3-5 psi on reservoir. 10-micron, returns filter furnishes only clean oil to all components of the system

## SERVICE CAPACITIES

Fuel tank 76.1 gal (288.0 L)

### DEF tank – Diesel Exhaust Fluid:

Usable 9.8 gal (37.1 L)  
Total 15.6 gal (58.9 L)

### Hydraulic system:

Reservoir 24.0 gal (90.8 L)  
Total 47.0 gal (178.0 L)

### Transmission:

Service w/ filter 9.0 gal (34.1 L)

### Front and rear axle:

Front axle 10.6 gal (40.0 L)  
Rear axle 10.6 gal (40.0 L)

Engine oil w/ filter 4.0 gal (15.1 L)

Cooling system 7.9 gal (30.0 L)

## OTHER SPECIFICATIONS

### Lift cylinder:

Bore diameter 5.5 in (140 mm)  
Rod diameter 3.0 in (76 mm)  
Stroke 33.3 in (846 mm)

### Dump cylinder:

Bore diameter 6.5 in (165 mm)  
Rod diameter 3.5 in (89 mm)  
Stroke 23.6 in (600 mm)

### Loader:

Z-Bar loader linkage; Single control for lift and tilt; Positive hold float; Automatic return-to-dig; Automatic height control; Automatic return-to-travel; Brake pedal transmission disconnect; Bucket position indicator on bucket.

### Cycle time:

Raise w/ rated bucket load 6.2 sec  
Dump w/ rated bucket load 1.2 sec  
Power down 2.9 sec  
Float down 2.5 sec

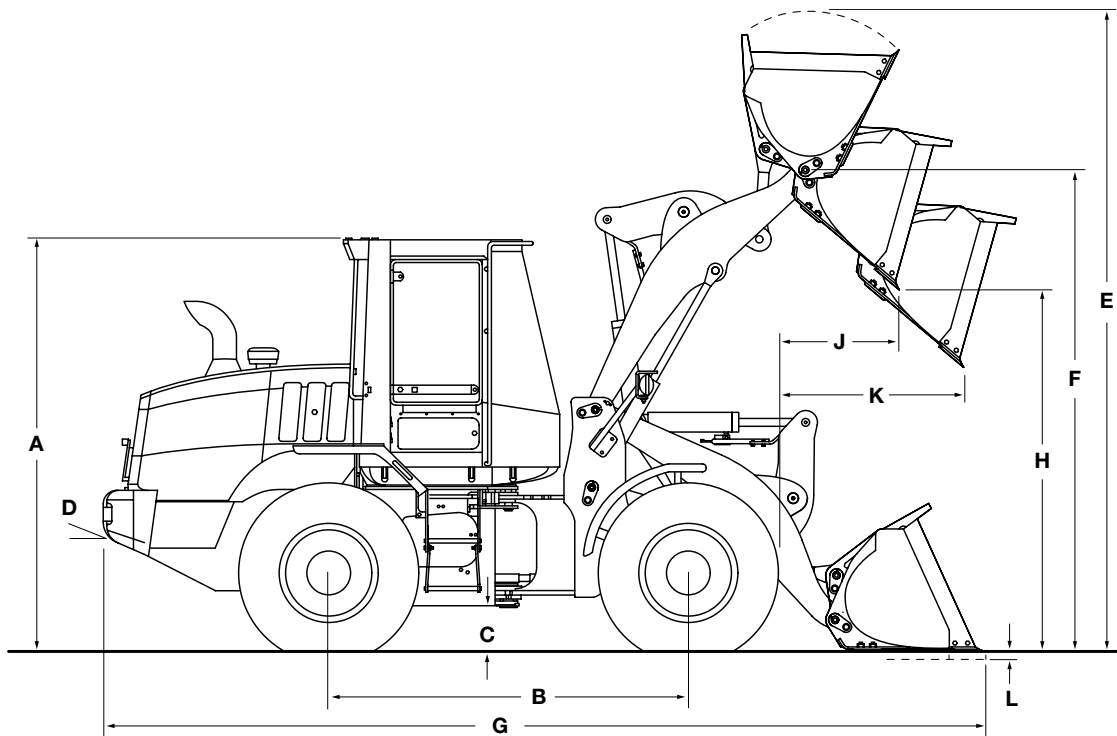

Line drawings are for illustrative purpose only and may not be exact representation of unit.

## DIMENSIONS

<b>A.</b> Height to top of ROPS cab	135.8 in (3 450 mm)
Height to drawbar	42.2 in (1 071 mm)
<b>B.</b> Wheelbase	131.5 in (3 340 mm)
<b>C.</b> Ground clearance	16.4 in (416 mm)
<b>D.</b> Angle of departure	32°
Width:	
Overall* without bucket	113.6 in (2 885 mm)
Centerline tread	87.8 in (2 230 mm)
Turning radius* – outside	237.5 in (6 032 mm)
Turning angle:	
From center	40°
Total angle	80°
Rear axle oscillation, total	24°

NOTE: \*Dimensions taken with 23.5R25 Michelin XHA2 tires. Additional dimensions on pages 4 through 8.

## WEIGHT ADJUSTMENTS

Select Options	Weight Adjustment	Tipping Load Adjustment Straight	Tipping Load Adjustment 40° Turn
Base counterweight	-1,678 lb (-761 kg)	-3,885 lb (-1 762 kg)	-3,278 lb (-1 487 kg)
L2BIAS tires	-948 lb (-430 kg)	-732 lb (-332 kg)	-646 lb (-293 kg)
L3BIAS tires	-313 lb (-142 kg)	-240 lb (-109 kg)	-212 lb (-96 kg)
ROPS Canopy	-295 lb (-134 kg)	-258 lb (-117 kg)	-249 lb (-113 kg)

NOTE: Unit equipped with Z-Bar loader arms, 4.25 yd<sup>3</sup> (3.2 m<sup>3</sup>) general purpose pin on bucket with bolt-on edge, 23.5-25 Michelin XHA2 tires, ROPS cab with heater and air conditioner, full counterweight, heavy-duty batteries, front and rear fenders, full fuel and 175 lb (79 kg) operator. Adjust select options from rated weight.

## PERFORMANCE DATA

<b>821F Z-Bar*</b>	<b>3.50 yd<sup>3</sup> HD Pin On (2.6 m<sup>3</sup>) Bucket with Bolt-on Edge</b>	<b>3.50 yd<sup>3</sup> HD Pin On (2.6 m<sup>3</sup>) Bucket with Teeth Only</b>	<b>4.25 yd<sup>3</sup> MD Pin On (3.2 m<sup>3</sup>) Bucket with Bolt-on Edge</b>
<b>E.</b> Operating height – fully raised with spillguard	210.1 in (5 336 mm)	209.6 in (5 325 mm)	216.4 in (5 496 mm)
<b>F.</b> Hinge pin height – fully raised	162.3 in (4 123 mm)	162.3 in (4 123 mm)	162.3 in (4 123 mm)
<b>G.</b> Overall length – bucket level on ground	303.1 in (7 700 mm)	308.8 in (7 844 mm)	309.4 in (7 859 mm)
Dump angle – fully raised	55°	55°	55°
<b>H.</b> Dump height – fully raised, 45° dump	121.5 in (3 086 mm)	118.0 in (2 996 mm)	117.4 in (2 983 mm)
<b>J.</b> Bucket reach – fully raised, 45° dump	38.8 in (985 mm)	43.6 in (1 107 mm)	43.6 in (1 107 mm)
<b>K.</b> Bucket reach – 7 ft 0 in (2.13 m) height, 45° dump	64.0 in (1 625 mm)	67.2 in (1 708 mm)	67.0 in (1 703 mm)
<b>L.</b> Dig depth – edge below ground	3.0 in (75 mm)	2.6 in (66 mm)	3.0 in (75 mm)
Operating load – ISO	13,871 lb (6 292 kg)	14,116 lb (6 403 kg)	13,614 lb (6 175 kg)
Operating load – SAE	12,893 lb (5 848 kg)	13,111 lb (5 947 kg)	12,630 lb (5 729 kg)
Maximum material density – ISO	4,033 lb/yd <sup>3</sup> (2 393 kg/m <sup>3</sup> )	4,406 lb/yd <sup>3</sup> (2 614 kg/m <sup>3</sup> )	3,283 lb/yd <sup>3</sup> (1 948 kg/m <sup>3</sup> )
Maximum material density – SAE	3,749 lb/yd <sup>3</sup> (2 224 kg/m <sup>3</sup> )	4,092 lb/yd <sup>3</sup> (2 428 kg/m <sup>3</sup> )	3,047 lb/yd <sup>3</sup> (1 808 kg/m <sup>3</sup> )
Tipping load – ISO:			
Straight	32,009 lb (14 519 kg)	32,571 lb (14 774 kg)	31,471 lb (14 275 kg)
40° turn	27,741 lb (12 583 kg)	28,232 lb (12 806 kg)	27,225 lb (12 349 kg)
Tipping load – SAE:			
Straight	30,466 lb (13 819 kg)	30,982 lb (14 053 kg)	29,921 lb (13 572 kg)
40° turn	25,785 lb (11 696 kg)	26,222 lb (11 894 kg)	25,261 lb (11 458 kg)
Lift capacity:			
Full height	22,544 lb (10 226 kg)	22,551 lb (10 229 kg)	22,203 lb (10 071 kg)
Maximum reach	30,430 lb (13 803 kg)	30,468 lb (13 820 kg)	30,073 lb (13 641 kg)
Ground	40,468 lb (18 356 kg)	40,737 lb (18 478 kg)	39,930 lb (18 112 kg)
Breakout force with tilt cylinder	40,658 lb (18 442 kg)	44,042 lb (19 977 kg)	35,338 lb (16 029 kg)
Loader clearance circle with bucket	519.3 in (13 190 mm)	523.0 in (13 284 mm)	522.8 in (13 279 mm)

<b>821F XR</b>	<b>3.50 yd<sup>3</sup> HD Pin On (2.6 m<sup>3</sup>) Bucket with Bolt-on Edge</b>	<b>3.50 yd<sup>3</sup> HD Pin On (2.6 m<sup>3</sup>) Bucket with Teeth Only</b>	<b>4.25 yd<sup>3</sup> MD Pin On (3.2 m<sup>3</sup>) Bucket with Bolt-on Edge</b>
<b>E.</b> Operating height – fully raised with spillguard	227.4 in (5 777 mm)	227.0 in (5 766 mm)	233.7 in (5 937 mm)
<b>F.</b> Hinge pin height – fully raised	179.7 in (4 564 mm)	179.7 in (4 564 mm)	179.7 in (4 564 mm)
<b>G.</b> Overall length – bucket level on ground	322.3 in (8 186 mm)	328.0 in (8 332 mm)	328.5 in (8 345 mm)
Dump angle – fully raised	49°	49°	49°
<b>H.</b> Dump height – fully raised, 45° dump	138.9 in (3 527 mm)	135.3 in (3 437 mm)	134.8 in (3 424 mm)
<b>J.</b> Bucket reach – fully raised, 45° dump	43.2 in (1 097 mm)	48.0 in (1 219 mm)	48.0 in (1 219 mm)
<b>K.</b> Bucket reach – 7 ft 0 in (2.13 m) height, 45° dump	80.9 in (2 055 mm)	84.4 in (2 143 mm)	84.2 in (2 139 mm)
<b>L.</b> Dig depth – edge below ground	5.6 in (142 mm)	5.2 in (133 mm)	5.6 in (142 mm)
Operating load – ISO	10,950 lb (4 967 kg)	11,116 lb (5 042 kg)	10,714 lb (4 860 kg)
Operating load – SAE	10,274 lb (4 660 kg)	10,421 lb (4 727 kg)	10,033 lb (4 551 kg)
Maximum material density – ISO	3,184 lb/yd <sup>3</sup> (1 889 kg/m <sup>3</sup> )	3,469 lb/yd <sup>3</sup> (2 058 kg/m <sup>3</sup> )	2,584 lb/yd <sup>3</sup> (1 533 kg/m <sup>3</sup> )
Maximum material density – SAE	2,987 lb/yd <sup>3</sup> (1 772 kg/m <sup>3</sup> )	3,253 lb/yd <sup>3</sup> (1 930 kg/m <sup>3</sup> )	2,420 lb/yd <sup>3</sup> (1 436 kg/m <sup>3</sup> )
Tipping load – ISO:			
Straight	25,481 lb (11 558 kg)	25,860 lb (11 730 kg)	24,992 lb (11 336 kg)
40° turn	21,901 lb (9 934 kg)	22,231 lb (10 084 kg)	21,429 lb (9 720 kg)
Tipping load – SAE:			
Straight	24,436 lb (11 084 kg)	24,791 lb (11 245 kg)	23,942 lb (10 860 kg)
40° turn	20,545 lb (9 319 kg)	20,842 lb (9 454 kg)	20,066 lb (9 102 kg)
Lift capacity:			
Full height	20,693 lb (9 386 kg)	20,695 lb (9 387 kg)	20,353 lb (9 232 kg)
Maximum reach	26,089 lb (11 834 kg)	26,138 lb (11 856 kg)	25,726 lb (11 669 kg)
Ground	30,918 lb (14 024 kg)	31,178 lb (14 142 kg)	30,369 lb (13 775 kg)
Breakout force with tilt cylinder	41,295 lb (18 731 kg)	44,743 lb (20 295 kg)	35,898 lb (16 283 kg)
Loader clearance circle with bucket	538.1 in (13 669 mm)	542.5 in (13 779 mm)	542.4 in (13 776 mm)

<b>821F</b>	<b>Z-Bar/XR</b>	<b>Z-Bar/XR</b>	<b>Z-Bar/XR</b>
Maximum rollback:			
Ground	41°/37°	41°/37°	41°/37°
Carry position	44°/43°	44°/43°	44°/43°
@ Maximum reach	54°/53°	54°/53°	54°/53°
@ Full height	59°/60°	59°/60°	59°/60°
Maximum grading angle with bucket – back dragging	59°/62°	60°/63°	60°/63°
SAE bucket capacity – struck	2.9 yd <sup>3</sup> (2.22 m <sup>3</sup> )	2.7 yd <sup>3</sup> (2.09 m <sup>3</sup> )	3.5 yd <sup>3</sup> (2.71 m <sup>3</sup> )
Heaped	3.4 yd <sup>3</sup> (2.63 m <sup>3</sup> )	3.2 yd <sup>3</sup> (2.45 m <sup>3</sup> )	4.1 yd <sup>3</sup> (3.17 m <sup>3</sup> )
Bucket width – outside	119.3 in (3 030 mm)	119.9 in (3 046 mm)	119.3 in (3 030 mm)
Bucket weight	3,109 lb (1 410 kg)	3,126 lb (1 418 kg)	3,441 lb (1 561 kg)

## PERFORMANCE DATA

<b>821F Z-Bar*</b>		<b>4.25 yd<sup>3</sup> MD Pin On (3.2 m<sup>3</sup>) Bucket with Teeth Only</b>	<b>4.50 yd<sup>3</sup> LD Pin On (3.4 m<sup>3</sup>) Bucket with Bolt-on Edge</b>	<b>3.5 yd<sup>3</sup> GP (2.7 m<sup>3</sup>) on Case Z-Bar Coupler Bucket with Bolt-on Edge</b>
<b>E.</b>	Operating height – fully raised with spillguard	215.5 in (5 474 mm)	217.7 in (5 530 mm)	216.3 in (5 494 mm)
<b>F.</b>	Hinge pin height – fully raised	162.3 in (4 123 mm)	162.3 in (4 123 mm)	162.2 in (4 121 mm)
<b>G.</b>	Overall length – bucket level on ground	308.6 in (7 838 mm)	310.8 in (7 894 mm)	313.5 in (7 962 mm)
	Dump angle – fully raised	55°	55°	55°
<b>H.</b>	Dump height – fully raised, 45° dump	117.9 in (2 995 mm)	116.6 in (2 961 mm)	114.8 in (2 916 mm)
<b>J.</b>	Bucket reach – fully raised, 45° dump	42.7 in (1 085 mm)	44.6 in (1 133 mm)	46.7 in (1 186 mm)
<b>K.</b>	Bucket reach – 7 ft 0 in (2.13 m) height, 45° dump	66.4 in (1 686 mm)	67.6 in (1 718 mm)	68.9 in (1 749 mm)
<b>L.</b>	Dig depth – edge below ground	3.1 in (80 mm)	3.0 in (75 mm)	3.0 in (75 mm)
	Operating load – ISO	13,704 lb (6 216 kg)	13,494 lb (6 121 kg)	12,209 lb (5 538 kg)
	Operating load – SAE	12,705 lb (5 763 kg)	12,507 lb (5 673 kg)	11,296 lb (5 124 kg)
	Maximum material density – ISO	3,435 lb/yd <sup>3</sup> (2 038 kg/m <sup>3</sup> )	3,044 lb/yd <sup>3</sup> (1 806 kg/m <sup>3</sup> )	3,550 lb/yd <sup>3</sup> (2 106 kg/m <sup>3</sup> )
	Maximum material density – SAE	3,186 lb/yd <sup>3</sup> (1 890 kg/m <sup>3</sup> )	2,822 lb/yd <sup>3</sup> (1 674 kg/m <sup>3</sup> )	3,283 lb/yd <sup>3</sup> (1 948 kg/m <sup>3</sup> )
Tipping load – ISO:	Straight	31,683 lb (14 371 kg)	31,206 lb (14 155 kg)	28,420 lb (12 891 kg)
	40° turn	27,408 lb (12 432 kg)	26,987 lb (12 241 kg)	24,418 lb (11 076 kg)
Tipping load – SAE:	Straight	30,102 lb (13 654 kg)	29,650 lb (13 449 kg)	26,982 lb (12 239 kg)
	40° turn	25,408 lb (11 525 kg)	25,014 lb (11 346 kg)	22,591 lb (10 247 kg)
Lift capacity:	Full height	22,174 lb (10 058 kg)	22,132 lb (10 039 kg)	20,768 lb (9 420 kg)
	Maximum reach	30,053 lb (13 632 kg)	29,983 lb (13 600 kg)	28,526 lb (12 939 kg)
	Ground	39,985 lb (18 137 kg)	39,654 lb (17 987 kg)	32,053 lb (14 539 kg)
	Breakout force with tilt cylinder	44,311 lb (20 099 kg)	34,348 lb (15 580 kg)	32,227 lb (14 618 kg)
	Loader clearance circle with bucket	522.9 in (13 282 mm)	523.6 in (13 299 mm)	525.1 in (13 338 mm)

<b>821F XR</b>		<b>4.25 yd<sup>3</sup> MD Pin On (3.2 m<sup>3</sup>) Bucket with Teeth Only</b>	<b>4.50 yd<sup>3</sup> LD Pin On (3.4 m<sup>3</sup>) Bucket with Bolt-on Edge</b>	<b>3.5 yd<sup>3</sup> GP (2.7 m<sup>3</sup>) on Case Z-Bar Coupler Bucket with Bolt-on Edge</b>
<b>E.</b>	Operating height – fully raised with spillguard	232.9 in (5 915 mm)	235.1 in (5 971 mm)	233.7 in (5 935 mm)
<b>F.</b>	Hinge pin height – fully raised	179.7 in (4 564 mm)	179.7 in (4 564 mm)	179.6 in (4 562 mm)
<b>G.</b>	Overall length – bucket level on ground	327.7 in (8 324 mm)	329.9 in (8 380 mm)	332.6 in (8 449 mm)
	Dump angle – fully raised	49°	49°	49°
<b>H.</b>	Dump height – fully raised, 45° dump	135.3 in (3 437 mm)	133.9 in (3 402 mm)	132.2 in (3 357 mm)
<b>J.</b>	Bucket reach – fully raised, 45° dump	47.2 in (1 198 mm)	49.1 in (1 246 mm)	51.1 in (1 298 mm)
<b>K.</b>	Bucket reach – 7 ft 0 in (2.13 m) height, 45° dump	83.5 in (2 122 mm)	84.9 in (2 156 mm)	86.2 in (2 190 mm)
<b>L.</b>	Dig depth – edge below ground	5.8 in (147 mm)	5.6 in (142 mm)	5.6 in (143 mm)
	Operating load – ISO	10,770 lb (4 885 kg)	10,617 lb (4 816 kg)	9,550 lb (4 332 kg)
	Operating load – SAE	10,080 lb (4 572 kg)	9,936 lb (4 507 kg)	8,911 lb (4 042 kg)
	Maximum material density – ISO	2,700 lb/yd <sup>3</sup> (1 602 kg/m <sup>3</sup> )	2,395 lb/yd <sup>3</sup> (1 421 kg/m <sup>3</sup> )	2,776 lb/yd <sup>3</sup> (1 647 kg/m <sup>3</sup> )
	Maximum material density – SAE	2,527 lb/yd <sup>3</sup> (1 499 kg/m <sup>3</sup> )	2,242 lb/yd <sup>3</sup> (1 330 kg/m <sup>3</sup> )	2,591 lb/yd <sup>3</sup> (1 537 kg/m <sup>3</sup> )
Tipping load – ISO:	Straight	25,122 lb (11 395 kg)	24,778 lb (11 239 kg)	22,485 lb (10 199 kg)
	40° turn	21,539 lb (9 770 kg)	21,235 lb (9 632 kg)	19,101 lb (8 664 kg)
Tipping load – SAE:	Straight	24,057 lb (10 912 kg)	23,726 lb (10 762 kg)	21,504 lb (9 754 kg)
	40° turn	20,159 lb (9 144 kg)	19,870 lb (9 013 kg)	17,822 lb (8 084 kg)
Lift capacity:	Full height	20,322 lb (9 218 kg)	20,283 lb (9 200 kg)	18,927 lb (8 585 kg)
	Maximum reach	25,712 lb (11 663 kg)	25,633 lb (11 627 kg)	24,149 lb (10 954 kg)
	Ground	30,402 lb (13 790 kg)	30,091 lb (13 649 kg)	27,992 lb (12 697 kg)
	Breakout force with tilt cylinder	45,003 lb (20 413 kg)	34,893 lb (15 827 kg)	32,745 lb (14 853 kg)
	Loader clearance circle with bucket	542.4 in (13 776 mm)	543.3 in (13 799 mm)	545.1 in (13 846 mm)

<b>821F</b>		<b>Z-Bar/XR</b>	<b>Z-Bar/XR</b>	<b>Z-Bar/XR</b>
Maximum rollback:	Ground	42°/38°	41°/37°	41°/37°
	Carry position	44°/43°	44°/43°	44°/43°
	@ Maximum reach	54°/53°	54°/53°	54°/53°
	@ Full height	59°/60°	59°/60°	59°/60°
	Maximum grading angle with bucket – back dragging	60°/63°	60°/63°	61°/63°
SAE bucket capacity – struck		3.4 yd <sup>3</sup> (2.63 m <sup>3</sup> )	3.8 yd <sup>3</sup> (2.89 m <sup>3</sup> )	2.9 yd <sup>3</sup> (2.20 m <sup>3</sup> )
	Heaped	4.0 yd <sup>3</sup> (3.05 m <sup>3</sup> )	4.4 yd <sup>3</sup> (3.39 m <sup>3</sup> )	3.4 yd <sup>3</sup> (2.63 m <sup>3</sup> )
	Bucket width – outside	119.9 in (3 046 mm)	119.3 in (3 030 mm)	119.3 in (3 030 mm)
	Bucket weight	3,486 lb (1 581 kg)	3,508 lb (1 591 kg)	4,808 lb (2 181 kg)

**PERFORMANCE DATA**

<b>821F Z-Bar*</b>	<b>3.5 yd<sup>3</sup> GP (2.7 m<sup>3</sup>) on Case Z-Bar Coupler Bucket with Teeth Only</b>	<b>3.5 yd<sup>3</sup> CB on CNH Z-bar Coupler (ACS Compatible) Bucket with Bolt-on Edge</b>	<b>3.5 yd<sup>3</sup> CB on CNH Z-bar Coupler (ACS Compatible) Bucket with Teeth Only</b>
<b>E.</b> Operating height – fully raised with spillguard	216.3 in (5 494 mm)	214.2 in (5 441 kg)	214.2 in (5 441 mm)
<b>F.</b> Hinge pin height – fully raised	162.2 in (4 121 mm)	162.2 in (4 121 mm)	162.2 in (4 121 mm)
<b>G.</b> Overall length – bucket level on ground	319.6 in (8 118 mm)	310.9 in (7 896 mm)	316.8 in (8 047 mm)
Dump angle – fully raised	55°	55°	55°
<b>H.</b> Dump height – fully raised, 45° dump	110.8 in (2 815 mm)	116.5 in (2 958 mm)	112.6 in (2 859 mm)
<b>J.</b> Bucket reach – fully raised, 45° dump	51.1 in (1 299 mm)	44.5 in (1 130 mm)	48.9 in (1 241 mm)
<b>K.</b> Bucket reach – 7 ft 0 in (2.13 m) height, 45° dump	71.3 in (1 810 mm)	67.5 in (1 714 mm)	69.9 in (1 776 mm)
<b>L.</b> Dig depth – edge below ground	3.2 in (81 mm)	3.1 in (80 mm)	3.3 in (84 mm)
Operating load – ISO	12,394 lb (5 622 kg)	12,375 lb (5 613 kg)	12,580 lb (5 706 kg)
Operating load – SAE	11,477 lb (5 206 kg)	11,455 lb (5 196 kg)	11,647 lb (5 283 kg)
Maximum material density – ISO	3,868 lb/yd <sup>3</sup> (2 295 kg/m <sup>3</sup> )	3,639 lb/yd <sup>3</sup> (2 159 kg/m <sup>3</sup> )	3,926 lb/yd <sup>3</sup> (2 329 kg/m <sup>3</sup> )
Maximum material density – SAE	3,582 lb/yd <sup>3</sup> (2 125 kg/m <sup>3</sup> )	3,369 lb/yd <sup>3</sup> (1 999 kg/m <sup>3</sup> )	3,636 lb/yd <sup>3</sup> (2 157 kg/m <sup>3</sup> )
Tipping load – ISO:			
Straight	28,812 lb (13 069 kg)	28,801 lb (13 064 kg)	29,249 lb (13 267 kg)
40° turn	24,789 lb (11 244 kg)	24,749 lb (11 226 kg)	25,161 lb (11 413 kg)
Tipping load – SAE:			
Straight	27,368 lb (12 414 kg)	27,357 lb (12 409 kg)	27,780 lb (12 601 kg)
40° turn	22,955 lb (10 412 kg)	22,910 lb (10 392 kg)	23,296 lb (10 567 kg)
Lift capacity:			
Full height	20,973 lb (9 513 kg)	20,774 lb (9 423 kg)	20,939 lb (9 498 kg)
Maximum reach	28,746 lb (13 039 kg)	28,565 lb (12 957 kg)	28,746 lb (13 039 kg)
Ground	33,477 lb (15 185 kg)	34,749 lb (15 762 kg)	36,502 lb (16 557 kg)
Breakout force with tilt cylinder	34,480 lb (15 640 kg)	33,982 lb (15 414 kg)	36,453 lb (16 535 kg)
Loader clearance circle with bucket	529.4 in (13 446 mm)	523.7 in (13 301 mm)	527.7 in (13 404 mm)

<b>821F XR</b>	<b>3.5 yd<sup>3</sup> GP (2.7 m<sup>3</sup>) on Case Z-Bar Coupler Bucket with Teeth Only</b>	<b>3.5 yd<sup>3</sup> CB on CNH Z-bar Coupler (ACS Compatible) Bucket with Bolt-on Edge</b>	<b>3.5 yd<sup>3</sup> CB on CNH Z-bar Coupler (ACS Compatible) Bucket with Teeth Only</b>
<b>E.</b> Operating height – fully raised with spillguard	233.7 in (5 936 mm)	231.6 in (5 882 mm)	231.6 in (5 882 mm)
<b>F.</b> Hinge pin height – fully raised	179.6 in (4 563 mm)	179.6 in (4 562 mm)	179.6 in (4 562 mm)
<b>G.</b> Overall length – bucket level on ground	338.7 in (8 604 mm)	330.0 in (8 382 mm)	335.9 in (8 532 mm)
Dump angle – fully raised	49°	49°	49°
<b>H.</b> Dump height – fully raised, 45° dump	128.2 in (3 256 mm)	133.8 in (3 399 mm)	130.0 in (3 301 mm)
<b>J.</b> Bucket reach – fully raised, 45° dump	55.6 in (1 412 mm)	48.9 in (1 243 mm)	53.3 in (1 354 mm)
<b>K.</b> Bucket reach – 7 ft 0 in (2.13 m) height, 45° dump	88.9 in (2 259 mm)	84.7 in (2 152 mm)	87.4 in (2 221 mm)
<b>L.</b> Dig depth – edge below ground	5.8 in (148 mm)	5.8 in (147 mm)	6.0 in (151 mm)
Operating load – ISO	9,714 lb (4 406 kg)	9,667 lb (4 385 kg)	9,833 lb (4 460 kg)
Operating load – SAE	9,070 lb (4 114 kg)	9,024 lb (4 093 kg)	9,182 lb (4 165 kg)
Maximum material density – ISO	3,032 lb/yd <sup>3</sup> (1 799 kg/m <sup>3</sup> )	2,843 lb/yd <sup>3</sup> (1 687 kg/m <sup>3</sup> )	3,069 lb/yd <sup>3</sup> (1 821 kg/m <sup>3</sup> )
Maximum material density – SAE	2,832 lb/yd <sup>3</sup> (1 680 kg/m <sup>3</sup> )	2,655 lb/yd <sup>3</sup> (1 575 kg/m <sup>3</sup> )	2,865 lb/yd <sup>3</sup> (1 700 kg/m <sup>3</sup> )
Tipping load – ISO:			
Straight	22,827 lb (10 354 kg)	22,758 lb (10 323 kg)	23,115 lb (10 485 kg)
40° turn	19,425 lb (8 811 kg)	19,335 lb (8 770 kg)	19,667 lb (8 921 kg)
Tipping load – SAE:			
Straight	21,839 lb (9 906 kg)	21,768 lb (9 874 kg)	22,115 lb (10 031 kg)
40° turn	18,140 lb (8 228 kg)	18,047 lb (8 186 kg)	18,364 lb (8 330 kg)
Lift capacity:			
Full height	19,132 lb (8 678 kg)	18,931 lb (8 587 kg)	19,094 lb (8 661 kg)
Maximum reach	24,374 lb (11 056 kg)	24,198 lb (10 976 kg)	24,385 lb (11 061 kg)
Ground	28,338 lb (12 854 kg)	28,305 lb (12 839 kg)	28,614 lb (12 979 kg)
Breakout force with tilt cylinder	35,027 lb (15 888 kg)	34,524 lb (15 660 kg)	37,027 lb (16 795 kg)
Loader clearance circle with bucket	550.0 in (13 970 mm)	543.3 in (13 801 mm)	548.0 in (13 920 mm)

<b>821F</b>	<b>Z-Bar/XR</b>	<b>Z-Bar/XR</b>	<b>Z-Bar/XR</b>
Maximum rollback:			
Ground	42°/38°	42°/38°	42°/38°
Carry position	44°/43°	44°/43°	44°/43°
@ Maximum reach	54°/53°	54°/53°	54°/53°
@ Full height	59°/60°	59°/60°	59°/60°
Maximum grading angle with bucket – back dragging	62°/65°	60°/63°	61°/64°
SAE bucket capacity – struck	2.7 yd <sup>3</sup> (2.09 m <sup>3</sup> )	2.9 yd <sup>3</sup> (2.20 m <sup>3</sup> )	2.7 yd <sup>3</sup> (2.10 m <sup>3</sup> )
Heaped	3.2 yd <sup>3</sup> (2.45 m <sup>3</sup> )	3.4 yd <sup>3</sup> (2.60 m <sup>3</sup> )	3.2 yd <sup>3</sup> (2.45 m <sup>3</sup> )
Bucket width – outside	119.9 in (3 046 mm)	119.3 in (3 030 mm)	119.9 in (3 046 mm)
Bucket weight	4,610 lb (2 091 kg)	4,815 lb (2 184 kg)	4,665 lb (2 116 kg)



## PERFORMANCE DATA

821F	Z-Bar*		XR
	3.0 yd <sup>3</sup> 4-IN-1® (2.3 m <sup>3</sup> ) on Case Z-Bar Coupler Bucket Only	3.0 yd <sup>3</sup> 4-IN-1® (2.3 m <sup>3</sup> ) on Case Z-Bar Coupler Bucket Only	
E. Operating height – fully raised with spillguard	217.2 in (5 516 mm)	234.5 in (5 957 mm)	
F. Hinge pin height – fully raised	162.2 in (4 120 mm)	179.6 in (4 561 mm)	
G. Overall length – bucket level on ground	309.5 in (7 861 mm)	328.4 in (8 342 mm)	
Dump angle – fully raised	55°	49°	
H. Dump height – fully raised, 45° dump	116.9 in (2 969 mm)	134.3 in (3 410 mm)	
J. Bucket reach – fully raised, 45° dump	41.8 in (1 061 mm)	46.2 in (1 174 mm)	
K. Bucket reach – 7 ft 0 in (2.13 m) height, 45° dump	65.0 in (1 650 mm)	82.2 in (2 087 mm)	
L. Dig depth – edge below ground	4.6 in (116 mm)	7.2 in (183 mm)	
Operating load – ISO	11,449 lb (5 193 kg)	8,779 lb (3 982 kg)	
Operating load – SAE	10,545 lb (4 783 kg)	8,146 lb (3 695 kg)	
Maximum material density – ISO	3,774 lb/yd <sup>3</sup> (2 239 kg/m <sup>3</sup> )	2,894 lb/yd <sup>3</sup> (1 717 kg/m <sup>3</sup> )	
Maximum material density – SAE	3,476 lb/yd <sup>3</sup> (2 062 kg/m <sup>3</sup> )	2,685 lb/yd <sup>3</sup> (1 593 kg/m <sup>3</sup> )	
Tipping load – ISO:			
Straight	26,903 lb (12 203 kg)	20,946 lb (9 501 kg)	
40° turn	22,897 lb (10 386 kg)	17,558 lb (7 964 kg)	
Tipping load – SAE:			
Straight	25,483 lb (11 559 kg)	19,974 lb (9 060 kg)	
40° turn	21,092 lb (9 567 kg)	16,290 lb (7 389 kg)	
Lift capacity:			
Full height	19,048 lb (8 640 kg)	17,207 lb (7 805 kg)	
Maximum reach	26,826 lb (12 168 kg)	22,461 lb (10 188 kg)	
Ground	32,708 lb (14 836 kg)	26,546 lb (12 041 kg)	
Breakout force with tilt cylinder	34,893 lb (15 827 kg)	35,424 lb (16 068 kg)	
Maximum rollback:			
Ground	42°	38°	
Carry position	44°	43°	
@ Maximum reach	54°	53°	
@ Full height	59°	60°	
Maximum grading angle with bucket – back dragging	60°	63°	
SAE bucket capacity – struck	2.6 yd <sup>3</sup> (1.98 m <sup>3</sup> )	2.6 yd <sup>3</sup> (1.98 m <sup>3</sup> )	
Heaped	3.0 yd <sup>3</sup> (2.32 m <sup>3</sup> )	3.0 yd <sup>3</sup> (2.32 m <sup>3</sup> )	
Bucket width – outside	119.3 in (3 030 mm)	119.3 in (3 030 mm)	
Bucket weight	6,534 lb (2 964 kg)	6,534 lb (2 964 kg)	
Loader clearance circle with bucket	523.0 in (13 285 mm)	542.6 in (13 781 mm)	

NOTE: \*Z-Bar performance data shown with full counterweight.

\*\*XT lift arm with buckets for ACS Pro Series 2000® size 30 HD coupler.

\*\*\*XT lift arm with bucket for Case coupler.

Performance data unit equipped with 20.5R25 Michelin XHA TL tires, ROPS cab with heater and air conditioner, full counterweight, standard batteries, front and rear fenders, full fuel and 175 lb (75 kg) operator. Specifications per SAE J732, J1234, J695, J742, and J818.

## 72 INCH FORKS ON CASE Z-BAR COUPLER

821F	Z-Bar	XR
<b>Dimensional</b>		
Fork length – Vertical front surface of tine to fork tip	72.0 in (1 829 mm)	72.0 in (1 829 mm)
Fork width – max. – Outside to outside of tine	96.0 in (2 438 mm)	96.0 in (2 438 mm)
Fork clearance @ full height – Ground to top of tine	152.0 in (3 861 mm)	169.4 in (4 302 mm)
Fork reach @ full height – Vertical front surface of tine to front of tire	33.9 in (862 mm)	38.3 in (974 mm)
Fork clearance @ max. reach – Ground to top of tine	70.6 in (1 794 mm)	70.6 in (1 792 mm)
Fork reach – max. – Vertical front surface of tine to front of tire	67.9 in (1 724 mm)	83.7 in (2 126 mm)
Fork reach @ ground – Vertical front surface of tine to front of tire	43.5 in (1 105 mm)	62.9 in (1 598 mm)
Fork load center – Vertical front surface of tine to load CG	36.0 in (914 mm)	36.0 in (914 mm)
<b>Operational</b>		
Fork attachment weight – includes coupler	4,162 lb (1 888 kg)	4,162 lb (1 888 kg)
Operating load – per EN 474-3:		
Rough terrain	9,374 lb (4 252 kg)	7,826 lb (3 550 kg)
Firm and level ground	12,498 lb (5 669 kg)	10,435 lb (4 733 kg)
Tipping load straight ISO	18,510 lb (8 396 kg)	15,622 lb (7 086 kg)
Tipping load @ 40° turn ISO	15,624 lb (7 087 kg)	13,043 lb (5 916 kg)
Operating weight	39,595 lb (17 960 kg)	40,437 lb (18 342 kg)

## STANDARD EQUIPMENT

### OPERATOR ENVIRONMENT

See page 1

### ENGINE

Case/FPT F4HFE613  
Tier 4 Final Certified  
Selectable work modes:  
Maximum Power  
Standard Power  
Economy Power  
Auto Power  
Turbocharger  
Charge air cooling  
Automatic belt tensioner  
Integral engine oil cooling  
Fuel filter with water trap  
Dual-element dry-type air cleaner  
Hydraulic-driven cooling fan  
Air-cooled radiator  
Mid-mounted cooling module  
Common rail electronic fuel injection

### DRIVETRAIN

4-wheel drive  
4F/3R Selectable autoshift/manual shift transmission  
Electronic Control Module – programmable, computer controlled proportional shifting with programmable gear selection  
Onboard diagnostics  
Single lever electronic shift control  
F/N/R switch in loader control handle  
Downshift button

## OPTIONAL EQUIPMENT

### OPERATOR ENVIRONMENT

Heated cloth-covered air suspension seat  
Cloth mechanical suspension seat  
Headrest  
3 in (76 mm) retractable seat belt  
Sound Shield noise suppression package  
Cab with heater only – no AC  
Radio-ready – 12 or 24-volt with auxiliary power – 12-volt  
AM/FM stereo radio  
Cab convenience package: ashtray, 24V cigar lighter and cell phone holder  
Rotating beacon  
Right hand brake pedal  
External rearview mirrors  
External rearview mirrors, heated  
In-cab accessory mount – no rear view camera  
Rear view camera with accessory mount  
Extra front-facing work lights

### HYDRAULICS

Auxiliary hydraulics  
Ride Control  
Secondary steering  
Joystick steering with and without secondary steering  
2-function loader valve with single access control

### DRIVETRAIN (CONTINUED)

Torque converter  
Limited-slip differentials – Z-Bar  
Heavy-duty axles – XR:  
Larger size rear axle with automatic hydraulically-actuated differential lock on front axle, open differential on rear axle. Recommended for applications on hard surfaces or with solid tires.  
Outboard planetary axles  
Transmission oil cooler  
Brake pedal transmission disconnect – declutch  
Hydraulic wet disc brakes  
Spring-applied hydraulic release parking brake  
Limp-Home Mode  
Greaseable rear axle trunnion  
3-piece rims

### HYDRAULICS

2-function loader valve with joystick control  
Low-effort steering  
Hydraulic driven cooling fan  
Diagnostic quick couplers  
Split flange hydraulic connections – 1 in or greater

### LOADER

See page 2 – Operating weight, Other specifications

### ELECTRICAL

Alternator and voltage regulator  
Electrical disconnect  
120 amp alternator

### ELECTRICAL (CONTINUED)

(2) 700 CCA 12-volt batteries  
Electric starter  
Lights:  
2 Front and 2 rear halogen flood lights  
2 Front driving headlights – high/low beam with integrated turn signals  
2 LED stop/tail lights with integrated turn signals  
Key start/stop switch  
Backup alarm  
Centrally located fuse box with all electrical circuits protected  
Remote jump start receptacle

### TELEMATICS

CASE SiteWatch™ Telematics – includes hardware and a 3-yr Advanced data subscription

### OTHER

Electric hood lift  
Front and rear fenders, partial coverage  
Heavy counterweight  
Drawbar hitch  
Articulation locking bar  
Lift arm locking bar  
Lift and tie-down points – front/rear  
Remote drain points  
Grouped remote-mounted ecology drains:  
Engine oil  
Engine coolant  
Hydraulic oil

### HYDRAULICS (CONTINUED)

3-function loader valve with 3 lever control or with joystick plus lever  
4-function loader valve with joystick and 2 lever control

### DRIVETRAIN

5F/3R Autoshift/manual shift transmission, lockup torque converter, PowerInch de-clutch  
Heavy-duty axles – Z-Bar:  
Larger size rear axle with automatic hydraulically-actuated differential lock on front axle, open differential on rear axle. Recommended for applications on hard surfaces or with solid tires.

Cold weather package:  
Heavy-duty (2) 950 CCA 12V batteries  
Grid heater  
Fuel heater  
Hydraulic oil cooler bypass  
Low temperature hydraulic oil  
Fast-warm hydraulic valve

### TIRES

23.5 x 25 L2 bias – dirt/traction  
23.5 x 25 L3 bias – rock  
23.5 R25 L2 radial – dirt/traction  
23.5 R25 L3 radial – rock  
23.5 R25 radial Michelin SnoPlus  
Spare wheels and tires  
Axle oscillation stops

### LOADER

XR extended reach version  
Attachment auxiliary hydraulics  
Coupler systems – JRB or ACS compatible  
Buckets – see pages 4 through 7  
4 – 1 clamp buckets  
Forks

### ADVANCED ENGINE AIR FILTRATION

Variable speed hydraulic reversing fan  
Full view air pre-cleaner  
Sy-Klone® ejective air pre-cleaner

### OTHER

Additional RH steps and platform with standard or wide fenders  
Side guards for rear frame  
Tool box – ground level access  
Light counterweight – Z-Bar  
Fire extinguisher  
License plate bracket  
12.4 mph (20 kph) maximum speed control  
Special paint  
Skid plate and transmission





NOTE: All specifications are stated in accordance with SAE Standards or Recommended Practices, where applicable.

NOTE: All engines meet current EPA emissions requirements.

IMPORTANT: Case Construction Inc. reserves the right to change these specifications without notice and without incurring any obligation relating to such change. Case Construction Inc. does not warrant the safety or reliability of attachments from other manufacturers.

CASE is a trademark registered in the United States and many other countries, owned by or licensed to CNH Industrial N.V., its subsidiaries or affiliates. CNH Industrial Capital is a trademark in the United States and many other countries, owned by or licensed to CNH Industrial N.V., its subsidiaries or affiliates.

Form No. CCE201503821F  
Replaces Form No. CCE201412821F

Printed in U.S.A.  
821F • Page 9 of 9



[www.casece.com](http://www.casece.com)

© 2015 CNH Industrial America LLC  
All Rights Reserved



All Case construction equipment is biodiesel ready.