

## ENGINE

Make	FPT
Model	F4HFE613T
Emissions Certification	Tier 4 Final
Type	4-stroke, turbocharged and air-to-air cooled
Cylinders	6-cylinder in-line
Bore/Stroke	4.09 x 5.20 in (104 x 132 mm)
Displacement	411 in <sup>3</sup> (6.7 L)
Fuel	#2 Diesel, #1 and #2 mixture permitted for cold temperature
Fuel injection	Direct injection – electronic
Fuel filter	Replaceable
Fuel pump	Bosch CR/CP3
Gradeability:	
Side-to-side	35°
Fore and aft	35°
Air filter	Dry type elements w/ warning restriction indicator
Mid-mount cooling module:	Mid-mount air/water
Fan – hydraulic driven:	
Style	8 blade puller
Diameter	32 in (813 mm)
Water pump	Integral
Engine oil pump operating angles ratings:	
Side-to-side	35°
Fore and aft	35°
Oil filtration	Replaceable
Engine speeds	RPM
Rated – full load	2000

### Horsepower:

Maximum Power Mode:	
Peak gross @ 2000 RPM	194 hp (145 kW)
Net rated @ 2000 RPM	178 hp (133 kW)
Peak net @ 2000 RPM	178 hp (133 kW)
Standard Power Mode:	
Peak gross @ 1700 RPM	176 hp (131 kW)
Net rated @ 2000 RPM	143 hp (107 kW)
Peak net @ 1600 RPM	162 hp (121 kW)
Economy Power Mode:	
Peak gross @ 1400 RPM	146 hp (109 kW)
Net rated @ 2000 RPM	121 hp (90 kW)
Peak net @ 1400 RPM	138 hp (103 kW)

NOTE: Gross horsepower and torque per SAE J1995.  
Net horsepower and torque per SAE J1349.

## ENGINE (cont.)

Torque – peak:	
Maximum Power Mode:	
Gross @ 1300 RPM	701 lb-ft (950 N·m)
Net @ 1300 RPM	674 lb-ft (914 N·m)
Standard Power Mode:	
Gross @ 1300 RPM	620 lb-ft (841 N·m)
Net @ 1300 RPM	594 lb-ft (805 N·m)
Economy Power Mode:	
Gross @ 1200 RPM	589 lb-ft (799 N·m)
Net @ 1200 RPM	566 lb-ft (768 N·m)

Torque rise:	
Maximum power range	37%

NOTE: Gross horsepower and torque per SAE J1995.  
Net horsepower and torque per SAE J1349.

## DRIVETRAIN

Transmission:	
4F/3R Proportional w/ Electronic Control Module torque sensing autoshift/manual shift and modulation	
Gears	Helical cut
Torque converter:	
Stall ratio – 4-speed	2.81:1
Stall ratio – 5-speed	2.42:1
Differential	Limited slip w/ 30% transfer on front and rear axles
Rear axle oscillation	24° total
Front axles:	
Differential ratio	3.4
Planetary ratio	6.0
Final axle ratio	20.2
Rear axles:	
Differential ratio	3.2
Planetary ratio	6.4
Final axle ratio	20.4

Heavy-duty axles – optional:  
Front axle equipped w/ locking differential  
Rear axle equipped w/ open differential

Planetaries	Outboard
-------------	----------

Service brakes:	
Hydraulically actuated, maintenance-free, multiple wet disc w/ accumulator to all four wheels	
Brake surface area:	
Front hub – each	600 in <sup>2</sup> (0.387 m <sup>2</sup> )
Rear hub – each	600 in <sup>2</sup> (0.387 m <sup>2</sup> )

Parking brakes:	
Spring-applied hydraulic release disc on transmission output shaft neutralizes power flow to wheels when engaged	

Travel speeds – 4-speed transmission:		
	Forward	Reverse
	mph (kph)	mph (kph)
1st	4.7 (7.6)	5.0 (8.0)
2nd	7.9 (12.8)	8.3 (13.4)
3rd	15.2 (24.5)	16.0 (25.7)
4th	23.5 (37.8)	—

NOTE: Travel speeds at full engine throttle w/ 23.5 x 25 L3 tires.

## DRIVETRAIN (cont.)

Travel speeds – 5-speed transmission:		
	Forward	Reverse
	mph (kph)	mph (kph)
1st	4.5 (7.2)	4.9 (7.9)
2nd	7.8 (12.6)	8.4 (13.5)
3rd	11.8 (19.0)	19.3 (31.1)
4th	18.3 (29.5)	—
5th	24.8 (40.0)	—

NOTE: Travel speeds at full engine throttle w/ 23.5 x 25 L3 tires.

## ELECTRICAL

Voltage	24 Volts, negative ground
Alternator	120 amp
Batteries (2)	12-volt

## OPERATOR ENVIRONMENT

ROPS/FOPS Cab w/ heat and AC; Key start; Articulated power steering w/ tilt column; Fully adjustable suspension seat; Foot throttle; 1-Lever loader control w/ wrist rest; Cup holder; Coat hook; 1 Interior rearview mirror; 2 in. (51 mm) retractable seat belt; Storage tray behind seat; Lunch box compartment; Single brake pedal; F-N-R shuttle switch; Glove box; Pressurized air filtering; Anti-glare window strip; Defroster; Side window partial/fully open; Dome light; Wipers, rear and intermittent front; Windshield washers, front and rear; Rubber floor mat; Horn.

### Displays/Gauges:

Analog:  
Transmission oil temperature; Hydraulic oil temperature; Fuel Level; Engine coolant temperature.

### LCD screen:

Hour meter; Engine speed; Travel speed; Time; Automatic transmission indication; Current gear selection; FNR indication; DeClutch indication; Engine mode indication; Trip computer; Fuel consumption; Multiple languages, Metric/English; Engine diagnostics; Transmission diagnostics; Warning prompts; Error reporting; DEF gauge; Diff. lock\*.

### Audible/Visual alarms:

Warning lights:  
Four-way flashers and turn signals; Brake pressure; Lamp/high beam indication; Grid heater\*.

NOTE: \*If equipped w/ option.

## OPERATOR ENVIRONMENT (cont.)

### Audible/Visual alarms:

#### Caution alarm:

Parking brake; Coolant temperature; Hydraulic oil temperature; Transmission oil temperature; Air filter; Transmission filter; Hydraulic filter; Alternator; Low fuel.

#### Critical alarm:

Engine oil pressure; Brake pressure; Steering pressure – w/ aux. steering\*; Coolant temperature; Hydraulic oil temperature; Transmission oil temperature.

#### Backup alarm

NOTE: \*If equipped w/ option.

## OPERATING WEIGHT

### Z-Bar

Unit equipped w/ 3.25 yd<sup>3</sup> (2.5 m<sup>3</sup>) MD pin on w/ bolt on edge; 20.5R25 XHA Michelin tires; ROPS cab w/ heater and A/C; Std. battery; Heavy counterweight – 2,764 lb (1 254 kg); Front and rear fenders; Lights; Full fuel/urea; 175 lb (79 kg) operator:

31,508 lb (14 292 kg)

### XT

Unit equipped w/ 3.0 yd<sup>3</sup> (2.3 m<sup>3</sup>) CNH GP w/ BOE and CNH coupler; 20.5R25 XHA Michelin tires; ROPS cab w/ heater and A/C; Std. battery; Heavy counterweight – 2,764 lb (1 254 kg); Front and rear fenders; Lights; Full fuel/urea; 175 lb (79 kg) operator:

32,567 lb (14 772 kg)

### XR

Unit equipped w/ 3.0 yd<sup>3</sup> (2.3 m<sup>3</sup>) pin on bucket w/ bolt on edge; 20.5R25 XHA Michelin tires; ROPS cab w/ heater and A/C; Std. battery; Heavy counterweight – 2,764 lb (1 254 kg); Front and rear fenders; Lights; Full fuel/urea; 175 lb (79 kg) operator:

32,064 lb (14 544 kg)

## HYDRAULICS

### Pump – steering/implement:

Closed center pressure/flow compensated

### Variable displacement – load-sensing:

31.7 gpm @ 2000 RPM  
(120 L/min @ 2000 RPM)

### Loader control valve:

Closed-center, sectional 2, 3 or 4-function w/ pilot control for lift, tilt and auxiliary hydraulics, electromagnetic detents in float, raise and rollback

### Loader auxiliary steering:

Hydraulic orbital center-pivot articulating w/ on-demand oil flow

### High pressure standby:

Implement 3,625 psi (25 000 kPa)  
Steering 3,499 psi (24 132 kPa)

### Filtration:

Filtered vent w/ relief on hydraulic reservoir, maintains 3-5 psi on reservoir, 10-micron, returns filter furnishes only clean oil to all components of the system

## SERVICE CAPACITIES

Fuel tank 65.0 gal (246.0 L)

### DEF tank – Diesel Exhaust Fluid:

Usable capacity 9.8 gal (37.1 L)  
Total 15.6 gal (58.9 L)

### Hydraulic system:

Reservoir 24.0 gal (90.8 L)  
Total 47.0 gal (177.8 L)

### Transmission:

Service w/ filter 9.0 gal (34.0 L)

### Front and rear axle:

Front axle 9.2 gal (35.0 L)  
Rear axle 6.1 gal (23.0 L)

### Front and rear axle – optional:

Front axle 9.2 gal (35.0 L)  
Rear axle 9.2 gal (35.0 L)

Engine oil w/ filter 4.0 gal (15.1 L)

Cooling system 7.5 gal (28.4 L)

## OTHER SPECIFICATIONS

### Lift cylinder:

Bore diameter 4.7 in (121 mm)  
Rod diameter 3.0 in (76 mm)  
Stroke 32.6 in (828 mm)

### Dump cylinder – Z-Bar and XR:

Bore diameter 5.7 in (146 mm)  
Rod diameter 3.0 in (76 mm)  
Stroke 24.8 in (629 mm)

### Dump cylinder – XT:

Bore diameter 4.5 in (114 mm)  
Rod diameter 2.3 in (57 mm)  
Stroke 33.7 in (857 mm)

### Loader:

Z-Bar loader linkage; Single control for lift and tilt; Positive hold float; Automatic return-to-dig; Automatic height control; Automatic return-to-travel; Brake pedal transmission disconnect; Bucket position indicator on bucket.

### Cycle time:

#### Raise w/ rated bucket load:

Z-Bar 5.2 sec  
XR 5.2 sec  
XT 5.2 sec

#### Dump w/ rated bucket load:

Z-Bar 1.2 sec  
XR 1.2 sec  
XT 1.3 sec

#### Power down:

Z-Bar 2.5 sec  
XR 2.5 sec  
XT 2.5 sec

#### Float down:

Z-Bar 2.4 sec  
XR 2.4 sec  
XT 2.4 sec

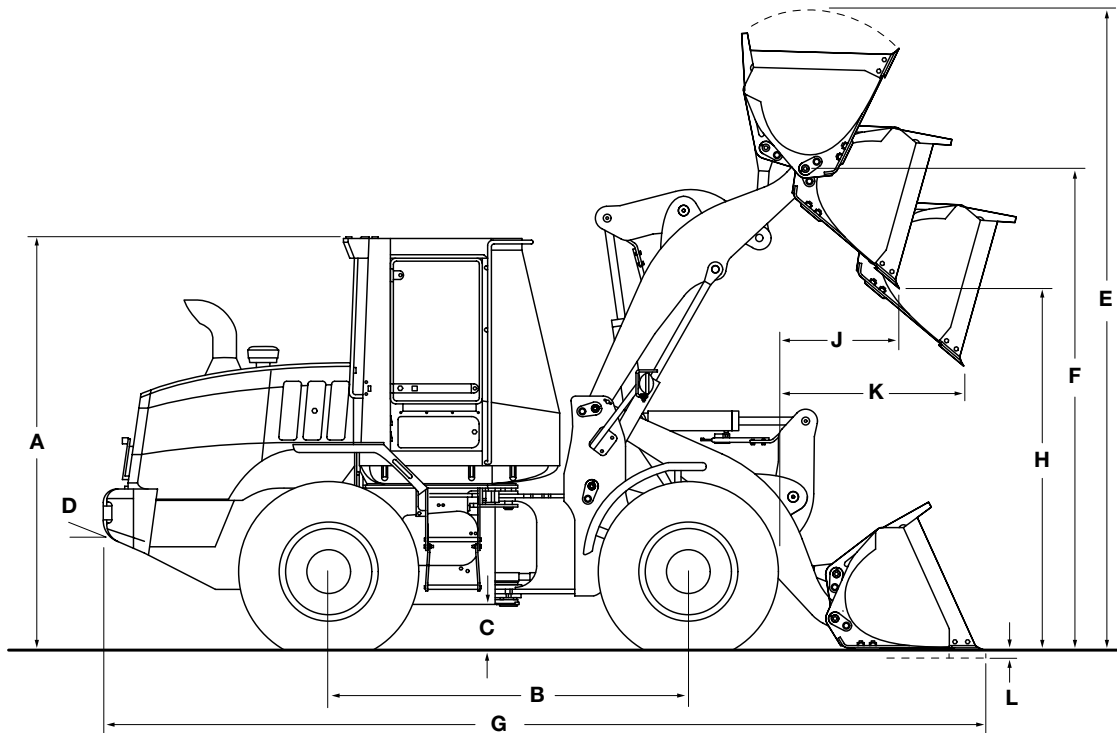

Line drawings are for illustrative purpose only and may not be exact representation of unit.

## DIMENSIONS

<b>A.</b> Height to top of ROPS cab	133.3 in (3 385 mm)
Height to drawbar	43.8 in (1 112 mm)
<b>B.</b> Wheelbase	128.1 in (3 253 mm)
<b>C.</b> Ground clearance	14.4 in (365 mm)
<b>D.</b> Angle of departure	32°
Width:	
Overall* without bucket	104.4 in (2 653 mm)
Centerline tread	79.9 in (2 030 mm)
Turning radius* – outside	226.4 in (5 750 mm)
Turning angle:	
From center	40°
Total angle	80°
Rear axle oscillation, total	24°

NOTE: \*Dimensions taken with 23.5R25 Michelin XHA2 tires. Additional dimensions on pages 4 through 8.

## WEIGHT ADJUSTMENTS

Select Options	Weight Adjustment	Tipping Load Adjustment Straight	Tipping Load Adjustment 40° Turn
20.5 x 25 12 ply L2 Goodyear	-556 lb (-252 kg)	-437 lb (-198 kg)	-386 lb (-175 kg)
20.5 x 25 12 ply L3 Goodyear	-227 lb (-103 kg)	-179 lb (-81 kg)	-159 lb (-72 kg)
20.5 R25 XTLA Michelin tires	-379 lb (-172 kg)	-298 lb (-135 kg)	-262 lb (-119 kg)
20.5 R25 RT-3B Goodyear	152 lb (69 kg)	117 lb (53 kg)	104 lb (47 kg)
Base Counterweight	-529 lb (-240 kg)	-1,208 lb (-548 kg)	-1,023 lb (-464 kg)
ROPS Canopy	-295 lb (-134 kg)	-340 lb (-154 kg)	-313 lb (-142 kg)

NOTE: Unit equipped with Z-Bar loader arms, 4.75 yd<sup>3</sup> (3.6 m<sup>3</sup>) pin on bucket with bolt-on edge, 23.5R25 Michelin XHA2 tires, ROPS cab with heater and air conditioner, full counterweight, heavy-duty batteries, front and rear fenders, full fuel and 175 lb (79 kg) operator. Adjust select options from rated weight.

## PERFORMANCE DATA

<b>721F Z-Bar*</b>	<b>3.0 yd<sup>3</sup> HD Pin On (2.3 m<sup>3</sup>) Bucket with Bolt-on Edge</b>	<b>3.0 yd<sup>3</sup> HD Pin On (2.3 m<sup>3</sup>) Bucket with Teeth Only</b>	<b>3.25 yd<sup>3</sup> MD Pin On (2.5 m<sup>3</sup>) Bucket with Bolt-on Edge</b>
SAE bucket capacity – struck Heaped	2.5 yd <sup>3</sup> (1.94 m <sup>3</sup> ) 3.0 yd <sup>3</sup> (2.30 m <sup>3</sup> )	2.4 yd <sup>3</sup> (1.85 m <sup>3</sup> ) 2.8 yd <sup>3</sup> (2.13 m <sup>3</sup> )	2.8 yd <sup>3</sup> (2.11 m <sup>3</sup> ) 3.3 yd <sup>3</sup> (2.49 m <sup>3</sup> )
Bucket width – outside	106.3 in (2 700 mm)	107.6 in (2 732 mm)	106.3 in (2 700 mm)
Bucket weight	2,506 lb (1 137 kg)	2,605 lb (1 182 kg)	2,614 lb (1 186 kg)
<b>E.</b> Operating height – fully raised with spillguard	203.5 in (5 169 mm)	203.5 in (5 169 mm)	205.9 in (5 229 mm)
<b>F.</b> Hinge pin height – fully raised	156.7 in (3 979 mm)	156.7 in (3 979 mm)	156.7 in (3 979 mm)
<b>G.</b> Overall length – bucket level on ground	299.1 in (7 596 mm)	305.0 in (7 748 mm)	301.1 in (7 648 mm)
Dump angle – fully raised	55°	55°	55°
<b>H.</b> Dump height – fully raised, 45° dump	116.7 in (2 963 mm)	112.8 in (2 864 mm)	115.4 in (2 930 mm)
<b>J.</b> Bucket reach – fully raised, 45° dump	42.8 in (1 086 mm)	47.1 in (1 196 mm)	44.3 in (1 125 mm)
<b>K.</b> Bucket reach – 7 ft 0 in (2.13 m) height, 45° dump	64.3 in (1 633 mm)	66.9 in (1 698 mm)	65.3 in (1 658 mm)
Operating load – ISO	11,687 lb (5 301 kg)	11,777 lb (5 342 kg)	11,607 lb (5 265 kg)
Operating load – SAE	10,609 lb (4 812 kg)	10,745 lb (4 874 kg)	10,524 lb (4 774 kg)
Maximum material density – ISO	3,883 lb/yd <sup>3</sup> (2 304 kg/m <sup>3</sup> )	4,229 lb/yd <sup>3</sup> (2 509 kg/m <sup>3</sup> )	3,570 lb/yd <sup>3</sup> (2 118 kg/m <sup>3</sup> )
Maximum material density – SAE	3,524 lb/yd <sup>3</sup> (2 091 kg/m <sup>3</sup> )	3,836 lb/yd <sup>3</sup> (2 276 kg/m <sup>3</sup> )	3,236 lb/yd <sup>3</sup> (1 920 kg/m <sup>3</sup> )
Tipping load – ISO:			
Straight	26,696 lb (12 109 kg)	26,918 lb (12 210 kg)	26,530 lb (12 034 kg)
40° turn	23,371 lb (10 601 kg)	23,556 lb (10,685 kg)	23,212 lb (10 529 kg)
Tipping load – SAE:			
Straight	25,022 lb (11 350 kg)	25,219 lb (11 439 kg)	24,846 lb (11 270 kg)
40° turn	21,219 lb (9 625 kg)	21,372 lb (9 694 kg)	21,048 lb (9 547 kg)
Lift capacity:			
Full height	16,288 lb (7 388 kg)	16,193 lb (7 345 kg)	16,180 lb (7 339 kg)
Maximum reach	22,518 lb (10 214 kg)	22,443 lb (10 180 kg)	22,406 lb (10 163 kg)
Ground	29,921 lb (13 572 kg)	30,091 lb (13 649 kg)	29,690 lb (13 467 kg)
Breakout force with tilt cylinder	32,906 lb (14 926 kg)	35,598 lb (16 147 kg)	31,383 lb (14 235 kg)
Maximum rollback:			
Ground	39°	40°	39°
Carry position	43°	43°	43°
@ Maximum reach	54°	54°	54°
@ Full height	57°	57°	57°
<b>L.</b> Dig depth	2.9 in (73 mm)	3.1 in (78 mm)	2.9 in (73 mm)
Maximum grading angle with bucket – back dragging	60°	61°	60°
Loader clearance circle with bucket	496.3 in (12 607 mm)	500.9 in (12 724 mm)	497.5 in (12 636 mm)

<b>721F XR</b>	<b>3.0 yd<sup>3</sup> HD Pin On (2.3 m<sup>3</sup>) Bucket with Bolt-on Edge</b>	<b>3.0 yd<sup>3</sup> HD Pin On (2.3 m<sup>3</sup>) Bucket with Teeth Only</b>	<b>3.25 yd<sup>3</sup> MD Pin On (2.5 m<sup>3</sup>) Bucket with Bolt-on Edge</b>
<b>E.</b> Operating height – fully raised with spillguard	219.1 in (5 564 mm)	219.0 in (5 563 mm)	221.4 in (5 623 mm)
<b>F.</b> Hinge pin height – fully raised	172.2 in (4 374 mm)	172.2 in (4 374 mm)	172.2 in (4 374 mm)
<b>G.</b> Overall length – bucket level on ground	313.2 in (7 955 mm)	319.1 in (8 106 mm)	315.2 in (8 006 mm)
Dump angle – fully raised	55°	55°	55°
<b>H.</b> Dump height – fully raised, 45° dump	132.2 in (3 358 mm)	128.3 in (3 259 mm)	130.9 in (3 324 mm)
<b>J.</b> Bucket reach – fully raised, 45° dump	42.8 in (1 087 mm)	47.1 in (1 197 mm)	44.3 in (1 126 mm)
<b>K.</b> Bucket reach – 7 ft 0 in (2.13 m) height, 45° dump	76.5 in (1 942 mm)	79.2 in (2 012 mm)	77.5 in (1 968 mm)
Operating load – ISO	9,784 lb (4 438 kg)	9,841 lb (4 464 kg)	9,709 lb (4 404 kg)
Operating load – SAE	8,960 lb (4 064 kg)	9,006 lb (4 085 kg)	8,878 lb (4 027 kg)
Maximum material density – ISO	3,251 lb/yd <sup>3</sup> (1 929 kg/m <sup>3</sup> )	3,533 lb/yd <sup>3</sup> (2 096 kg/m <sup>3</sup> )	2,987 lb/yd <sup>3</sup> (1 772 kg/m <sup>3</sup> )
Maximum material density – SAE	2,977 lb/yd <sup>3</sup> (1 766 kg/m <sup>3</sup> )	3,233 lb/yd <sup>3</sup> (1 980 kg/m <sup>3</sup> )	2,731 lb/yd <sup>3</sup> (1 620 kg/m <sup>3</sup> )
Tipping load – ISO:			
Straight	22,474 lb (10 194 kg)	22,617 lb (10 259 kg)	22,315 lb (10 122 kg)
40° turn	19,568 lb (8 876 kg)	19,683 lb (8 928 kg)	19,418 lb (8 808 kg)
Tipping load – SAE:			
Straight	21,222 lb (9 626 kg)	21,347 lb (9 683 kg)	21,056 lb (9 551 kg)
40° turn	17,917 lb (8 127 kg)	18,012 lb (8 170 kg)	17,758 lb (8 055 kg)
Lift capacity:			
Full height	15,181 lb (6 886 kg)	15,084 lb (6 842 kg)	15,073 lb (6 837 kg)
Maximum reach	20,201 lb (9 163 kg)	20,122 lb (9 127 kg)	20,086 lb (9 111 kg)
Ground	24,934 lb (11 310 kg)	25,033 lb (11 355 kg)	24,727 lb (11 216 kg)
Breakout force with tilt cylinder	32,732 lb (14 847 kg)	35,415 lb (16 064 kg)	31,215 lb (14 159 kg)
Loader clearance circle with bucket	508.7 in (12 922 mm)	513.9 in (13 052 mm)	510.1 in (12 956 mm)

## PERFORMANCE DATA

<b>721F Z-Bar*</b>	<b>3.25 yd<sup>3</sup> MD Pin On (2.5 m<sup>3</sup>) Bucket with Teeth Only</b>	<b>3.5 yd<sup>3</sup> LD Pin On (2.7 m<sup>3</sup>) Bucket with Bolt-on Edge</b>	<b>3.5 yd<sup>3</sup> (2.7 m<sup>3</sup>) Bucket with Grapple with Bolt-on Edge</b>
SAE bucket capacity – struck	2.6 yd <sup>3</sup> (2.00 m <sup>3</sup> )	3.0 yd <sup>3</sup> (2.30 m <sup>3</sup> )	3.0 yd <sup>3</sup> (2.32 m <sup>3</sup> )
Heaped	3.0 yd <sup>3</sup> (2.30 m <sup>3</sup> )	3.5 yd <sup>3</sup> (2.68 m <sup>3</sup> )	3.5 yd <sup>3</sup> (2.67 m <sup>3</sup> )
Bucket width – outside	107.6 in (2 732 mm)	106.3 in (2 700 mm)	106.3 in (2 700 mm)
Bucket weight	2,700 lb (1 225 kg)	2,822 lb (1 280 kg)	4,366 lb (1 981 kg)
<b>E.</b> Operating height – fully raised with spillguard	205.8 in (5 228 mm)	208.6 in (5 297 mm)	208.1 in (5 286 mm)
<b>F.</b> Hinge pin height – fully raised	156.7 in (3 979 mm)	156.7 in (3 979 mm)	156.6 in (3 977 mm)
<b>G.</b> Overall length – bucket level on ground	307.1 in (7 800 mm)	303.5 in (7 708 mm)	303.5 in (7 710 mm)
Dump angle – fully raised	55°	55°	55°
<b>H.</b> Dump height – fully raised, 45° dump	111.5 in (2 831 mm)	113.8 in (2 891 mm)	113.7 in (2 889 mm)
<b>J.</b> Bucket reach – fully raised, 45° dump	48.6 in (1 235 mm)	46.1 in (1 171 mm)	46.1 in (1 171 mm)
<b>K.</b> Bucket reach – 7 ft 0 in (2.13 m) height, 45° dump	67.8 in (1 721 mm)	66.4 in (1 686 mm)	66.3 in (1 685 mm)
Operating load – ISO	11,706 lb (5 310 kg)	11,461 lb (5 199 kg)	10,527 lb (4 775 kg)
Operating load – SAE	10,606 lb (4 811 kg)	10,375 lb (4 706 kg)	9,436 lb (4 280 kg)
Maximum material density – ISO	3,892 lb/yd <sup>3</sup> (2 309 kg/m <sup>3</sup> )	3,274 lb/yd <sup>3</sup> (1 943 kg/m <sup>3</sup> )	3,015 lb/yd <sup>3</sup> (1 789 kg/m <sup>3</sup> )
Maximum material density – SAE	3,526 lb/yd <sup>3</sup> (2 092 kg/m <sup>3</sup> )	2,964 lb/yd <sup>3</sup> (1 759 kg/m <sup>3</sup> )	2,702 lb/yd <sup>3</sup> (1 603 kg/m <sup>3</sup> )
Tipping load – ISO:			
Straight	26,769 lb (12 142 kg)	26,116 lb (11 896 kg)	24,315 lb (11 029 kg)
40° turn	23,413 lb (10 620 kg)	22,921 lb (10 397 kg)	21,055 lb (9 550 kg)
Tipping load – SAE:			
Straight	25,058 lb (11 366 kg)	24,540 lb (11 131 kg)	22,622 lb (10 261 kg)
40° turn	21,213 lb (9 622 kg)	20,752 lb (9 413 kg)	18,869 lb (8 559 kg)
Lift capacity:			
Full height	16,098 lb (7 302 kg)	15,972 lb (7 245 kg)	14,427 lb (6 544 kg)
Maximum reach	22,342 lb (10 134 kg)	22,189 lb (10 065 kg)	20,615 lb (9 351 kg)
Ground	29,872 lb (13 550 kg)	29,337 lb (13 307 kg)	27,315 lb (12 390 kg)
Breakout force with tilt cylinder	33,805 lb (15 344 kg)	29,692 lb (13 486 kg)	27,977 lb (12 690 kg)
Maximum rollback:			
Ground	40°	39°	39°
Carry position	43°	43°	43°
@ Maximum reach	54°	54°	54°
@ Full height	57°	57°	57°
<b>L.</b> Dig depth	3.1 in (78 mm)	2.9 in (74 mm)	3.0 in (76 mm)
Maximum grading angle with bucket – back dragging	61°	60°	60°
Loader clearance circle with bucket	502.1 in (12 754 mm)	498.9 in (12 671 mm)	498.9 in (12 671 mm)

<b>721F XR</b>	<b>3.25 yd<sup>3</sup> MD Pin On (2.5 m<sup>3</sup>) Bucket with Teeth Only</b>	<b>3.5 yd<sup>3</sup> LD Pin On (2.7 m<sup>3</sup>) Bucket with Bolt-on Edge</b>	<b>3.5 yd<sup>3</sup> (2.7 m<sup>3</sup>) Bucket with Grapple with Bolt-on Edge</b>
<b>E.</b> Operating height – fully raised with spillguard	221.4 in (5 623 mm)	224.1 in (5 692 mm)	223.6 in (5 680 mm)
<b>F.</b> Hinge pin height – fully raised	172.2 in (4 374 mm)	172.2 in (4 374 mm)	172.1 in (4 372 mm)
<b>G.</b> Overall length – bucket level on ground	321.1 in (8 157 mm)	317.6 in (8 066 mm)	317.6 in (8 068 mm)
Dump angle – fully raised	55°	55°	55°
<b>H.</b> Dump height – fully raised, 45° dump	127.0 in (3 226 mm)	129.4 in (3 286 mm)	129.3 in (3 284 mm)
<b>J.</b> Bucket reach – fully raised, 45° dump	48.7 in (1 236 mm)	46.1 in (1 172 mm)	46.1 in (1 172 mm)
<b>K.</b> Bucket reach – 7 ft 0 in (2.13 m) height, 45° dump	80.2 in (2 037 mm)	78.7 in (1 998 mm)	78.7 in (1 998 mm)
Operating load – ISO	9,773 lb (4 433 kg)	9,572 lb (4 342 kg)	8,671 lb (3 933 kg)
Operating load – SAE	8,933 lb (4 052 kg)	8,739 lb (3 964 kg)	7,831 lb (3 552 kg)
Maximum material density – ISO	3,250 lb/yd <sup>3</sup> (1 928 kg/m <sup>3</sup> )	2,736 lb/yd <sup>3</sup> (1 623 kg/m <sup>3</sup> )	2,483 lb/yd <sup>3</sup> (1 473 kg/m <sup>3</sup> )
Maximum material density – SAE	2,969 lb/yd <sup>3</sup> (1 762 kg/m <sup>3</sup> )	2,497 lb/yd <sup>3</sup> (1 482 kg/m <sup>3</sup> )	2,243 lb/yd <sup>3</sup> (1 331 kg/m <sup>3</sup> )
Tipping load – ISO:			
Straight	22,474 lb (10 194 kg)	22,031 lb (9 993 kg)	20,194 lb (9 160 kg)
40° turn	19,546 lb (8 866 kg)	19,143 lb (8 683 kg)	17,341 lb (7 866 kg)
Tipping load – SAE:			
Straight	21,197 lb (9 615 kg)	20,770 lb (9 421 kg)	18,922 lb (8 583 kg)
40° turn	17,864 lb (8 103 kg)	17,480 lb (7 929 kg)	15,664 lb (7 105 kg)
Lift capacity:			
Full height	14,990 lb (6 799 kg)	14,865 lb (6 743 kg)	13,320 lb (6 042 kg)
Maximum reach	20,022 lb (9 082 kg)	19,870 lb (9 013 kg)	18,922 lb (8 300 kg)
Ground	24,839 lb (11 267 kg)	24,405 lb (11 070 kg)	22,478 lb (10 196 kg)
Breakout force with tilt cylinder	33,653 lb (15 265 kg)	29,573 lb (13 414 kg)	27,820 lb (12 619 kg)
Loader clearance circle with bucket	515.2 in (13 087 mm)	511.7 in (12 996 mm)	511.7 in (12 996 mm)



## PERFORMANCE DATA

<b>721F Z-Bar*</b>	<b>5.5 yd<sup>3</sup> LD Pin On (4.2 m<sup>3</sup>) Bucket with Bolt-on Edge</b>	<b>3.0 yd<sup>3</sup> GP (2.3 m<sup>3</sup>) Bucket on CNH Z-Bar Coupler with Bolt-on Edge</b>	<b>3.0 yd<sup>3</sup> GP (2.3 m<sup>3</sup>) Bucket on CNH Z-Bar Coupler with Teeth Only</b>
SAE bucket capacity – struck	5.5 yd <sup>3</sup> (4.20 m <sup>3</sup> )	2.5 yd <sup>3</sup> (1.92 m <sup>3</sup> )	2.4 yd <sup>3</sup> (1.85 m <sup>3</sup> )
Heaped	5.5 yd <sup>3</sup> (4.20 m <sup>3</sup> )	2.9 yd <sup>3</sup> (2.25 m <sup>3</sup> )	2.8 yd <sup>3</sup> (2.13 m <sup>3</sup> )
Bucket width – outside	106.3 in (2 700 mm)	106.3 in (2 700 mm)	107.6 in (2 732 mm)
Bucket weight	3,025 lb (1 372 kg)	3,721 lb (1 688 kg)	3,559 lb (1 614 kg)
<b>E.</b> Operating height – fully raised with spillguard	223.2 in (5 669 mm)	211.0 in (5 359 mm)	211.0 in (5 360 mm)
<b>F.</b> Hinge pin height – fully raised	156.7 in (3 979 mm)	156.6 in (3 978 mm)	156.6 in (3 978 mm)
<b>G.</b> Overall length – bucket level on ground	319.6 in (8 119 mm)	309.8 in (7 868 mm)	315.7 in (8 020 mm)
Dump angle – fully raised	55°	55°	55°
<b>H.</b> Dump height – fully raised, 45° dump	103.0 in (2 617 mm)	109.7 in (2 787 mm)	105.9 in (2 689 mm)
<b>J.</b> Bucket reach – fully raised, 45° dump	56.7 in (1 441 mm)	50.9 in (1 293 mm)	55.2 in (1 403 mm)
<b>K.</b> Bucket reach – 7 ft 0 in (2.13 m) height, 45° dump	71.3 in (1 811 mm)	69.2 in (1 757 mm)	71.4 in (1 814 mm)
Operating load – ISO	10,754 lb (4 878 kg)	10,185 lb (4 620 kg)	10,379 lb (4 708 kg)
Operating load – SAE	9,711 lb (4 405 kg)	9,217 lb (4 181 kg)	9,396 lb (4 262 kg)
Maximum material density – ISO	1,959 lb/yd <sup>3</sup> (1 162 kg/m <sup>3</sup> )	3,462 lb/yd <sup>3</sup> (2 054 kg/m <sup>3</sup> )	3,727 lb/yd <sup>3</sup> (2 211 kg/m <sup>3</sup> )
Maximum material density – SAE	1,768 lb/yd <sup>3</sup> (1 049 kg/m <sup>3</sup> )	3,132 lb/yd <sup>3</sup> (1 858 kg/m <sup>3</sup> )	3,373 lb/yd <sup>3</sup> (2 001 kg/m <sup>3</sup> )
Tipping load – ISO:			
Straight	24,652 lb (11 182 kg)	23,444 lb (10 634 kg)	23,861 lb (10 823 kg)
40° turn	21,506 lb (9 755 kg)	20,371 lb (9 240 kg)	20,759 lb (9 416 kg)
Tipping load – SAE:			
Straight	23,040 lb (10 451 kg)	21,954 lb (9 958 kg)	22,346 lb (10 136 kg)
40° turn	19,422 lb (8 810 kg)	18,433 lb (8 361 kg)	18,792 lb (8 524 kg)
Lift capacity:			
Full height	15,759 lb (7 148 kg)	15,005 lb (6 806 kg)	15,173 lb (6 882 kg)
Maximum reach	21,879 lb (9 924 kg)	21,060 lb (9 552 kg)	21,248 lb (9 638 kg)
Ground	27,959 lb (12 682 kg)	26,962 lb (12 230 kg)	27,342 lb (12 402 kg)
Breakout force with tilt cylinder	22,293 lb (10 112 kg)	26,375 lb (11 964 kg)	28,237 lb (12 808 kg)
Maximum rollback:			
Ground	40°	39°	39°
Carry position	43°	43°	43°
@ Maximum reach	54°	54°	54°
@ Full height	57°	57°	57°
<b>L.</b> Dig depth	4.3 in (110 mm)	3.0 in (75 mm)	3.1 in (80 mm)
Maximum grading angle with bucket – back dragging	65°	60°	62°
Loader clearance circle with bucket	508.8 in (12 923 mm)	502.8 in (12 770 mm)	507.6 in (12 893 mm)

<b>721F XR</b>	<b>5.5 yd<sup>3</sup> LD Pin On (4.2 m<sup>3</sup>) Bucket with Bolt-on Edge</b>	<b>3.0 yd<sup>3</sup> GP (2.3 m<sup>3</sup>) Bucket on Z-Bar Coupler with Bolt-on Edge</b>	<b>3.0 yd<sup>3</sup> GP (2.3 m<sup>3</sup>) Bucket on Z-Bar Coupler with Teeth Only</b>
<b>E.</b> Operating height – fully raised with spillguard	238.7 in (6 064 mm)	226.5 in (5 754 mm)	226.5 in (5 754 mm)
<b>F.</b> Hinge pin height – fully raised	172.2 in (4 373 mm)	172.1 in (4 372 mm)	172.2 in (4 373 mm)
<b>G.</b> Overall length – bucket level on ground	333.6 in (8 473 mm)	323.9 in (8 226 mm)	329.8 in (8 377 mm)
Dump angle – fully raised	55°	55°	55°
<b>H.</b> Dump height – fully raised, 45° dump	118.6 in (3 012 mm)	125.3 in (3 182 mm)	121.4 in (3 083 mm)
<b>J.</b> Bucket reach – fully raised, 45° dump	56.8 in (1 442 mm)	50.9 in (1 294 mm)	55.3 in (1 404 mm)
<b>K.</b> Bucket reach – 7 ft 0 in (2.13 m) height, 45° dump	84.3 in (2 140 mm)	81.7 in (2 075 mm)	84.2 in (2 138 mm)
Operating load – ISO	9,001 lb (4 083 kg)	8,494 lb (3 853 kg)	8,662 lb (3 929 kg)
Operating load – SAE	8,197 lb (3 718 kg)	7,743 lb (3 512 kg)	7,901 lb (1 845 kg)
Maximum material density – ISO	1,638 lb/yd <sup>3</sup> (972 kg/m <sup>3</sup> )	2,887 lb/yd <sup>3</sup> (1 713 kg/m <sup>3</sup> )	3,110 lb/yd <sup>3</sup> (1 845 kg/m <sup>3</sup> )
Maximum material density – SAE	1,492 lb/yd <sup>3</sup> (885 kg/m <sup>3</sup> )	2,631 lb/yd <sup>3</sup> (1 561 kg/m <sup>3</sup> )	2,836 lb/yd <sup>3</sup> (1 683 kg/m <sup>3</sup> )
Tipping load – ISO:			
Straight	20,765 lb (9 419 kg)	19,695 lb (8 933 kg)	20,051 lb (9 095 kg)
40° turn	18,005 lb (8 167 kg)	16,991 lb (7 707 kg)	17,324 lb (7 858 kg)
Tipping load – SAE:			
Straight	19,548 lb (8 867 kg)	19,563 lb (8 882 kg)	18,904 lb (8 575 kg)
40° turn	16,394 lb (7 436 kg)	15,485 lb (7 024 kg)	15,801 lb (7 167 kg)
Lift capacity:			
Full height	14,654 lb (6 647 kg)	13,903 lb (6 306 kg)	14,072 lb (6 383 kg)
Maximum reach	19,570 lb (8 877 kg)	18,758 lb (8 508 kg)	18,944 lb (8 593 kg)
Ground	23,269 lb (10 554 kg)	22,412 lb (10 166 kg)	22,734 lb (10 312 kg)
Breakout force with tilt cylinder	22,198 lb (10 069 kg)	26,226 lb (11 896 kg)	28,082 lb (12 738 kg)
Loader clearance circle with bucket	523.0 in (13 285 mm)	516.2 in (13 111 mm)	521.5 in (13 247 mm)

**PERFORMANCE DATA****721F Z-Bar\*****2.6 yd<sup>3</sup> (1.9 m<sup>3</sup>) 4-IN-1® Bucket on CNH Z-Bar coupler**

SAE bucket capacity – struck	2.2 yd <sup>3</sup> (1.71 m <sup>3</sup> )
Heaped	2.6 yd <sup>3</sup> (1.98 m <sup>3</sup> )
Bucket width – outside	106.3 in (2 700 mm)
Bucket weight	5,000 lb (2 268 kg)
<b>E.</b> Operating height – fully raised with spillguard	211.5 in (5 371 mm)
<b>F.</b> Hinge pin height – fully raised	156.5 in (3 976 mm)
<b>G.</b> Overall length – bucket level on ground	302.5 in (7 684 mm)
Dump angle – fully raised	55°
<b>H.</b> Dump height – fully raised, 45° dump	114.4 in (2 905 mm)
<b>J.</b> Bucket reach – fully raised, 45° dump	45.3 in (1 150 mm)
<b>K.</b> Bucket reach – 7 ft 0 in (2.13 m) height, 45° dump	65.8 in (1 671 mm)
Operating load – ISO	10,027 lb (4 548 kg)
Operating load – SAE	9,006 lb (4 085 kg)
Maximum material density – ISO	3,872 lb/yd <sup>3</sup> (2 297 kg/m <sup>3</sup> )
Maximum material density – SAE	3,477 lb/yd <sup>3</sup> (2 063 kg/m <sup>3</sup> )
Tipping load – ISO:	
Straight	23,223 lb (10 534 kg)
40° turn	20,053 lb (9 096 kg)
Tipping load – SAE:	
Straight	21,643 lb (9 817 kg)
40° turn	18,9010 lb (8 169 kg)
Lift capacity:	
Full height	13,750 lb (6 237 kg)
Maximum reach	19,886 lb (9 020 kg)
Ground	26,464 lb (12 004 kg)
Breakout force with tilt cylinder	30,119 lb (13 662 kg)
Maximum rollback:	
Ground	39°
Carry position	43°
@ Maximum reach	54°
@ Full height	57°
<b>L.</b> Dig depth	3.0 in (77 mm)
Maximum grading angle with bucket – back dragging	59°
Loader clearance circle with bucket	498.5 in (12 661 mm)

**721F XR****2.6 yd<sup>3</sup> GP (1.9 m<sup>3</sup>) 4-IN-1® Bucket on Z-Bar coupler**

<b>E.</b> Operating height – fully raised with spillguard	227.0 in (5 765 mm)
<b>F.</b> Hinge pin height – fully raised	172.1 in (4 371 mm)
<b>G.</b> Overall length – bucket level on ground	316.6 in (8 042 mm)
Dump angle – fully raised	55°
<b>H.</b> Dump height – fully raised, 45° dump	129.9 in (3 299 mm)
<b>J.</b> Bucket reach – fully raised, 45° dump	45.3 in (1 151 mm)
<b>K.</b> Bucket reach – 7 ft 0 in (2.13 m) height, 45° dump	78.1 in (1 983 mm)
Operating load – ISO	8,236 lb (3 736 kg)
Operating load – SAE	7,447 lb (3 378 kg)
Maximum material density – ISO	3,180 lb/yd <sup>3</sup> (1 887 kg/m <sup>3</sup> )
Maximum material density – SAE	2,877 lb/yd <sup>3</sup> (1 707 kg/m <sup>3</sup> )
Tipping load – ISO:	
Straight	19,251 lb (8 732 kg)
40° turn	16,471 lb (7 471 kg)
Tipping load – SAE:	
Straight	18,060 lb (8 192 kg)
40° turn	14,897 lb (6 757 kg)
Lift capacity:	
Full height	12,647 lb (5 737 kg)
Maximum reach	17,575 lb (7 972 kg)
Ground	21,740 lb (9 861 kg)
Breakout force with tilt cylinder	29,950 lb (13 585 kg)
Loader clearance circle with bucket	511.2 in (12 984 mm)

## PERFORMANCE DATA

721F XT	3.0 yd <sup>3</sup> GP (2.3 m <sup>3</sup> ) Bucket with CNH XT Coupler (JRB Compatible) with Bolt-On Edge	3.0 yd <sup>3</sup> GP (2.3 m <sup>3</sup> ) Bucket on CNH XT Coupler (JRB Compatible) with Teeth Only	2.6 yd <sup>3</sup> GP (2.0 m <sup>3</sup> ) 4-IN-1® Bucket on CNH XT Coupler
E. Operating height – fully raised with spillguard	217.3 in (5 519 mm)	217.3 in (5 519 mm)	217.4 in (5 522 mm)
F. Hinge pin height – fully raised	163.8 in (4 160 mm)	163.8 in (4 160 mm)	163.7 in (4 158 mm)
G. Overall length – bucket level on ground	312.2 in (7 931 mm)	318.2 in (8 083 mm)	305.0 in (7 747 mm)
Dump angle – fully raised	55°	55°	55°
H. Dump height – fully raised, 45° dump	115.0 in (2 921 mm)	111.1 in (2 822 mm)	119.6 in (3 038 mm)
J. Bucket reach – fully raised, 45° dump	50.4 in (1 279 mm)	54.6 in (1 386 mm)	44.6 in (1 133 mm)
K. Bucket reach – 7 ft 0 in (2.13 m) height, 45° dump	72.1 in (1 832 mm)	74.4 in (1 889 mm)	68.5 in (1 739 mm)
Operating load – ISO	9,879 lb (4 481 kg)	10,071 lb (4 568 kg)	9,689 lb (4 395 kg)
Operating load – SAE	8,924 lb (4 048 kg)	9,101 lb (4 128 kg)	8,686 lb (3 940 kg)
Maximum material density – ISO	3,358 lb/yd <sup>3</sup> (1 992 kg/m <sup>3</sup> )	3,615 lb/yd <sup>3</sup> (2 145 kg/m <sup>3</sup> )	3,742 lb/yd <sup>3</sup> (2 220 kg/m <sup>3</sup> )
Maximum material density – SAE	3,032 lb/yd <sup>3</sup> (1 799 kg/m <sup>3</sup> )	3,266 lb/yd <sup>3</sup> (1 938 kg/m <sup>3</sup> )	3,354 lb/yd <sup>3</sup> (1 990 kg/m <sup>3</sup> )
Tipping load – ISO:			
Straight	22,683 lb (10 289 kg)	23,093 lb (10 475 kg)	22,392 lb (10 157 kg)
40° turn	19,758 lb (8 962 kg)	20,139 lb (9 135 kg)	19,379 lb (8 790 kg)
Tipping load – SAE:			
Straight	21,222 lb (9 626 kg)	14,996 lb (6 802 kg)	20,847 lb (9 456 kg)
40° turn	17,846 lb (8 095 kg)	18,204 lb (8 257 kg)	17,372 lb (7 880 kg)
Lift capacity:			
Full height	14,288 lb (6 481 kg)	14,526 lb (6 589 kg)	13,325 lb (6 044 kg)
Maximum reach	19,989 lb (9 067 kg)	20,186 lb (9 156 kg)	18,838 lb (8 545 kg)
Ground	31,028 lb (14 074 kg)	30,988 lb (14 056 kg)	29,363 lb (13 319 kg)
Breakout force with tilt cylinder	27,860 lb (12 637 kg)	29,853 lb (13 541 kg)	31,837 lb (14 441 kg)
Loader clearance circle with bucket	613.9 in (15 592 mm)	499.5 in (12 687 mm)	492.9 in (12 519 mm)

NOTE: \*Z-Bar performance data shown with full counterweight.

Performance data unit equipped with 20.5R25 Michelin XHA TL tires, ROPS cab with heater and A/C, full counterweight, standard batteries, front and rear fenders, full fuel and 175 lb (75 kg) operator. Specifications per SAE J732, J1234, J695, J742 and J818.

## FORKS

	721F Z-Bar	721F XT	721F XR
Fork attachment weight including coupler	2,663 lb (1 208 kg)	2,385 lb (1 082 kg)	2,663 lb (1 208 kg)
Operating load – per EN 474-3:			
Rough terrain	8,356 lb (3 790 kg)	8,289 lb (3 760 kg)	7,355 lb (3 336 kg)
Firm and level ground	199.0 in (5 054 mm)	197.4 in (5 013 mm)	175.2 in (4 449 mm)
Tipping load straight ISO	291.7 in (7 410 mm)	288.6 in (7 330 mm)	258.3 in (6 561 mm)
Tipping load at 40° turn ISO	248.7 in (6 317 mm)	246.7 in (6 266 mm)	218.9 in (5 561 mm)
Unit operating mass	31,559 lb (14 315 kg)	31,500 lb (14 288 kg)	32,040 lb (14 533 kg)



## STANDARD EQUIPMENT

### OPERATOR ENVIRONMENT

See page 1

### ENGINE

Case/FPT F4HFE613T

Tier 4 Final Certified

Selectable work modes:

- Maximum Power
- Standard Power
- Economy Power
- Auto Power

Turbocharger

Charge air cooling

Automatic belt tensioner

Integral engine oil cooling

Fuel filter with water trap

Dual-element dry-type air cleaner

Hydraulic-driven cooling fan

Air-cooled radiator

Mid-mounted cooling module

Common rail electronic fuel injection

### DRIVETRAIN

4-wheel drive

4F/3R Selectable autoshift/manual shift transmission

Electronic Control Module – programmable, computer controlled proportional shifting with programmable gear selection

Onboard diagnostics

Single lever electronic shift control

F/N/R switch in loader control handle

### DRIVETRAIN (continued)

Downshift button

Torque converter

Limited-slip differentials – Z-Bar

Heavy-duty axles – XT/XR:  
with auto-locking front differential,  
rear conventional differential and  
with bronze sintered brake pads

Outboard planetary axles

Transmission oil cooler

Brake pedal transmission disconnect – declutch

Hydraulic wet disc brakes

Spring-applied hydraulic release parking brake

Limp-Home Mode

Greasable rear axle trunnion

3-piece rims

### HYDRAULICS

2-function loader valve  
with joystick control

Low-effort steering

Hydraulic driven cooling fan

Diagnostic quick couplers

Split flange hydraulic connections –  
1 in or greater

### LOADER

See page 2 – Operating weight, Other specifications

### ELECTRICAL

Alternator and voltage regulator

Electrical disconnect

### ELECTRICAL (continued)

120 amp alternator

(2) 700 CCA 12-volt batteries

Electric starter

Lights:

- 2 Front and 2 rear halogen flood lights
- 2 Front driving headlights – high/low beam with integrated turn signals
- 2 LED stop/tail lights with integrated turn signals

Key start/stop switch

Backup alarm

Centrally located fuse box  
with all electrical circuits protected

Remote jump start receptacle

### TELEMATICS

CASE SiteWatch™ Telematics – includes hardware and a 3-yr Advanced data subscription

### OTHER

Electric hood lift

Front and rear fenders, partial coverage

Heavy counterweight

Drawbar hitch

Articulation locking bar

Lift arm locking bar

Lift and tie-down points – front/rear

Remote drain points

Grouped remote-mounted ecology drains:  
Engine oil  
Engine coolant  
Hydraulic oil

## OPTIONAL EQUIPMENT

### OPERATOR ENVIRONMENT

Heated cloth-covered air suspension seat

Cloth mechanical suspension seat

Headrest

3 in (76 mm) retractable seat belt

Sound Shield noise suppression package

Cab with heater only – no AC

Radio-ready – 12 or 24-volt  
with auxiliary power – 12-volt

AM/FM stereo radio

Cab convenience package: ashtray, 24V cigar lighter and cell phone holder

Rotating beacon

Right hand brake pedal

External rearview mirrors

External rearview mirrors, heated

In-cab accessory mount – no rear view camera

Rear view camera with accessory mount

Extra front-facing work lights

### HYDRAULICS

Auxiliary hydraulics

Ride Control

Secondary steering

Joystick steering with and without secondary steering

2-function loader valve with single access control

3-function loader valve with 3 lever control or with joystick plus lever

### DRIVETRAIN

5F/3R Autoshift/manual shift transmission, lockup torque converter, PowerInch de-clutch

Heavy-duty axles – Z-Bar:  
with auto-locking front differential,  
rear conventional differential and  
with bronze sintered brake pads

Cold weather package:

- Heavy-duty (2) 950 CCA 12V batteries
- Grid heater
- Fuel heater
- Hydraulic oil cooler bypass
- Low temperature hydraulic oil
- Fast-warm hydraulic valve

### TIRES

20.5-25 16 PR L2 bias – dirt/traction

20.5-25 16 PR L3 bias – rock

20.5 R25 L2 radial – dirt/traction

20.5 R25 L3 radial – rock

20.5 R25 radial Michelin SnoPlus

20.5 R25 radial Bridgestone Snow Wedge

SolidFlex HD solid tires on adapter rims

Spare wheels and tires

Axle oscillation stops

### LOADER

XR extended reach version

XT tool carrier version

Attachment auxiliary hydraulics

Coupler systems – JRB or ACS compatible

Buckets – see pages 4 through 8

4 – 1 clamp buckets

Forks

### ADVANCED ENGINE AIR FILTRATION

Heavy Debris cooling system:

- Slanted cooling module cover
- Auto reversing fan
- Sy-Klone® ejective air pre-cleaner
- Increased cooling fin spacing
- Added cooling module sealing

Variable speed hydraulic reversing fan

Full view air pre-cleaner

Sy-Klone® ejective air pre-cleaner

### OTHER

Additional RH steps and platform w/ standard or wide fenders

Side guards for rear frame

Tool box – ground level access

Light counterweight – Z-Bar

Fire extinguisher

License plate bracket

12.4 mph (20 kph) maximum speed control

Special paint

### GUARDING

Skid plate, transmission and front chassis bottom guards

Windscreen guard

Specialized guarding package:

- Windscreen, articulation, front cover, chassis bottom, skid plate, transmission, lift cylinder, front lights, fuel tank, metal wrapped hoses and cylinder debris ejectors



NOTE: All specifications are stated in accordance with SAE Standards or Recommended Practices, where applicable.

NOTE: All engines meet current EPA emissions requirements.

IMPORTANT: Case Construction Inc. reserves the right to change these specifications without notice and without incurring any obligation relating to such change. Case Construction Inc. does not warrant the safety or reliability of attachments from other manufacturers.

CASE is a trademark registered in the United States and many other countries, owned by or licensed to CNH Industrial N.V., its subsidiaries or affiliates. CNH Industrial Capital is a trademark in the United States and many other countries, owned by or licensed to CNH Industrial N.V., its subsidiaries or affiliates.

Form No. CCE201503721F  
Replaces Form No. CCE201411721F

Printed in U.S.A.  
721F • Page 10 of 10



[www.casece.com](http://www.casece.com)

© 2015 CNH Industrial America LLC  
All Rights Reserved



All Case construction equipment is biodiesel ready.